

**BA368C**  
**Intrinsically safe**  
**externally powered**  
**panel mounting**  
**counter, timer, tachometer**  
**and clock**  
issue 11

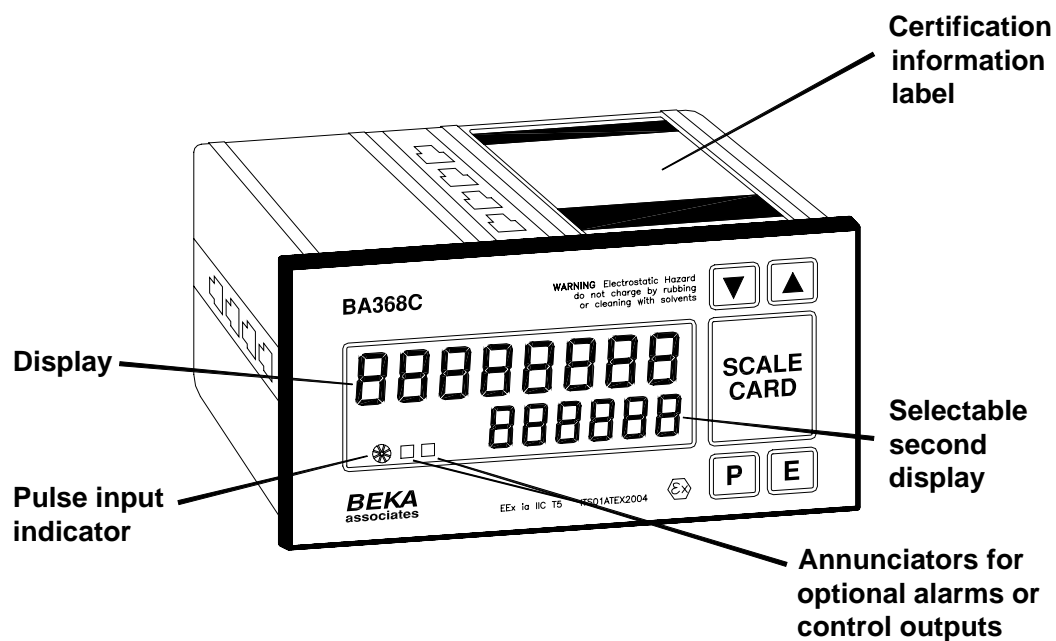

## CONTENTS

### 1. Common features

- 1.1 Structure of instruction manual
- 1.2 Operation
  - 1.2.1 Counter
  - 1.2.2 Timer
  - 1.2.3 Tachometer
  - 1.2.4 Clock
- 1.3 Initialisation
- 1.4 Intrinsic safety certification
  - 1.4.1 ATEX certification
  - 1.4.2 Power supply
  - 1.4.3 Pulse input terminals
  - 1.4.4 Remote reset terminals
  - 1.4.5 Zones, gas groups & T rating
  - 1.4.6 Certification label information
- 1.5 Installation
  - 1.5.1 Location
  - 1.5.2 Installation procedure
  - 1.5.3 EMC
- 1.6 Programming
  - 1.6.1 Security override link
- 1.7 Servicing
  - 1.7.1 Routine maintenance
  - 1.7.2 Guarantee
- 1.8 Customer comments
- 1.9 Accessories
  - 1.9.1 Scale card
  - 1.9.2 Tag number
  - 1.9.3 Optional control outputs / alarm outputs
    - 1.9.3.1 Solid state output
    - 1.9.3.2 Intrinsic safety
  - 1.9.4 Optional pulse output
    - 1.9.4.1 Intrinsic safety
  - 1.9.5 Optional 4/20mA output
    - 1.9.5.1 Intrinsic safety
  - 1.9.6 Optional display backlight

### Appendix 1 FM Approval for use in the USA

- 2. Use as a Counter
- 3. Use as a Timer
- 4. Use as a Tachometer
- 5. Use as a Clock

**Please read section 1 plus the section describing the function that you wish to use.**

The BA368C is CE marked to show compliance with the European Explosive Atmospheres Directive 94/9/EC and the European EMC Directive 2004/108/EC

## 1 COMMON FEATURES

The BA368C is a multifunction intrinsically safe panel-mounting instrument that may be programmed on-site as a counter, timer, tachometer or as a clock. The instrument has been certified intrinsically safe by European Notified Body Intertek Testing Services (ITS) to the ATEX Directive 94/9/EC allowing installation in most hazardous areas.

For use in the USA the BA368C has FM intrinsic safety and nonincendive approval – see Appendix 1.

Housed in a robust 72 x 144 panel-mounting DIN enclosure, the BA368C has an IP65 front panel and is supplied with a gasket to seal the joint between the instrument and the panel.

### 1.1 STRUCTURE OF INSTRUCTION MANUAL

This instruction manual is divided into five sections. The first covers the common features

**Please read section 1  
plus the section  
describing the function  
that you wish to use.**

of the instrument. The remaining are self contained sections each describing one of the BA368C functions.

1. Common features of the instrument including installation, intrinsic safety and accessories.
2. Use as a counter
3. Use as a timer
4. Use as a tachometer
5. Use as a clock

### 1.2 OPERATION

Fig 1.1 shows a simplified block diagram of the BA368C. The instrument may be programmed on-site as a counter, timer, tachometer or as a clock. The two inputs may be individually configured to accept voltage, contact, open collector or 2-wire proximity detector inputs. Accessories include a pulse output, 4/20mA analogue output and two solid state control outputs.

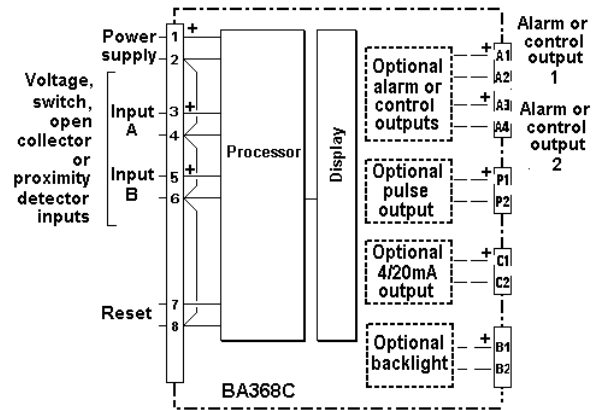

Fig 1.1 Simplified block diagram of BA368C

#### 1.2.1 Counter

When configured as a counter the BA368C will accept pulses on one or both inputs and may be programmed to display:

Input A + Input B

Input A - Input B

Input A, direction controlled by input B

Input A and Input B quadrature input  
(for position sensing)

Optional alarms, a pulse output and an analogue 4/20mA output are available

See section 2 of this manual for a detailed description of counter functions.

#### 1.2.2 Timer

The timer functions may be started and stopped from input A alone, inputs A and B, or from the front panel pushbuttons. Elapsed or remaining time may be displayed in hh:mm or hh:mm:ss format. The instrument will normally be supplied with two optional solid state control outputs.

See section 3 of this manual for a detailed description of the timer functions.

#### 1.2.3 Tachometer

When programmed as a tachometer the BA368C has one input which may be conditioned to operate with most types of pulse output transducer. The instrument will display rotational speed per second, minute or hour, or linear speed in engineering units. To assist with routine maintenance, a runtime counter records the number of hours the monitored machinery has been operating. Optional alarms and an analogue 4/20mA output are available.

See section 4 of this manual for a detailed description of the tachometer functions.

### 1.2.4 Clock

When programmed as a digital clock the BA368C will display local time within a hazardous area. The two optional solid state control outputs may be programmed to turn on and off twice during each 24 hour period.

See section 5 of this manual for a detailed description of the clock functions.

### 1.3 INITIALISATION

Each time power is applied to the BA368C initialisation is performed. After a short delay the following display sequence occurs:

All segments of the display are activated for about 2 seconds.

The product firmware and version number are shown on the top display and the current instrument function i.e. Countr, ELAPSE, tACHO or CLOC are displayed on the lower display for 2 seconds.

The BA368C starts to function using the calibration information stored in the permanent memory.

### 1.4 INTRINSIC SAFETY CERTIFICATION

#### 1.4.1 ATEX certification

The BA368C has been issued with EC-Type Examination Certificate number ITS01ATEX2004 by Notified Body Intertek Testing Services (ITS) confirming compliance with the European ATEX Directive 94/9/EC for Group II, Category 1, gas atmospheres, EEx ia IIC T5. The instrument bears the Community Mark and subject to local codes of practice, may be installed in any of the European Economic Area (EEA) member countries. i.e. Austria, Belgium, Denmark, Finland, France, Germany, Greece, Ireland, Italy, Luxembourg, The Netherlands, Norway, Portugal, Spain, Sweden and the United Kingdom. ATEX certificates are also accepted in Iceland, Liechtenstein, Switzerland and the Czech Republic.

This manual describes installations which conform with BS EN60079:Part14 Electrical Installation in Hazardous Areas. When designing systems for installation outside the UK, the local Code of Practice should be consulted.

#### 1.4.2 Power supply

When installed in a hazardous area the BA368C must be powered via a Zener barrier or galvanic isolator from a dc supply located in the safe area.

The input safety parameter for terminals 1 and 2 are:

$$\begin{aligned} U_i &= 28\text{V dc} \\ I_i &= 100\text{mA dc} \\ P_i &= 0.7\text{W} \end{aligned}$$

Any certified Zener barrier or galvanic isolator with output safety parameters within these limits may be used. Two system certificates provide guidance to help selection of suitable devices. The maximum equivalent capacitance and inductance between terminals 1 and 2 is:

$$\begin{aligned} C_i &= 20\text{nF} \\ L_i &= 20\mu\text{H} \end{aligned}$$

When installing a system not covered by the BA368C system certificates, these figures must be subtracted from the maximum cable parameters for the certified device powering the BA368C.

#### 1.4.3 Pulse input terminals

The BA368C has two identical inputs designated A (terminals 3 & 4), and B (terminals 5 & 6). Each may be connected to a switch, open collector or certified intrinsically safe 2-wire proximity detector. The safety parameters of each input are:

$$\begin{aligned} U_i &= 28\text{V dc} \\ I_i &= 100\text{mA dc} \\ P_i &= 0.7\text{W} \end{aligned}$$

$$\begin{aligned} U_o &= 10.5\text{V dc} \\ I_o &= 9.2\text{mA dc} \\ P_o &= 24\text{mW} \end{aligned}$$

**Note:** when programmed as a tachometer only one input may be used and when programmed as a clock neither of the inputs are available.

Hazardous area mechanically operated switches comply with the requirements for *simple apparatus* and may be directly connected to either input. Similarly, optically isolated open collector outputs that comply with the requirements for *simple apparatus* may also be directly connected to either input.

The BA368C system certificates specify some of the intrinsically safe 2-wire proximity detectors that may be connected directly to the two instrument inputs. Other certified intrinsically safe detectors may be used providing that the input safety parameters of the detector are less than the BA368C output parameters.

Voltage pulses may be connected to one or both inputs. They must be from a certified intrinsically safe source within the hazardous area, or connected via a Zener barrier or galvanic isolator from any safe area pulse source. The output parameters of the barrier or isolator must be less than the BA368C input parameters.

To comply with certification requirements, all transducers and associated field wiring connected to the BA368C input terminals must be able to withstand an ac test voltage of 500V rms to earth or frame of the apparatus for one minute. The maximum equivalent capacitance and inductance between the pulse input terminals 3 & 4 and 5 & 6 is:

$$\begin{aligned} C_i &= 20\text{nF} \\ L_i &= 20\mu\text{H} \end{aligned}$$

When installing systems not covered by the BA368C system certificates, these figures must be subtracted from the maximum cable parameters for the certified device connected to the BA368C input.

#### 1.4.4 Remote reset terminals

When programmed as a counter, timer or clock the BA368C display can be reset or synchronised by connecting terminals 7 and 8 together for more than one second. These terminals have the following input and output safety parameters:

$$\begin{aligned} U_i &= 28\text{V dc} \\ I_i &= 100\text{mA dc} \\ P_i &= 0.7\text{W} \\ \\ U_o &= 3.8\text{V dc} \\ I_o &= 1.7\text{mA dc} \\ P_o &= 2.0\text{mW} \end{aligned}$$

The display may be reset from within the hazardous area by any mechanically operated switch connected directly to terminals 7 & 8.

To reset the display from the safe area a Zener barrier or intrinsically safe relay is required to transfer the contact closure into the hazardous area. Almost any intrinsically safe relay with certification permitting the contacts to be connected to equipment in the hazardous area may be used. A positive diode return Zener barrier may also be used. The system certificates list suitable devices and define the maximum cable parameters.

#### 1.4.5 Zones, gas groups and T rating

The BA368C has been certified compliant with the requirements for Group II, Category 1 G, EEx ia IIC T5 (Tamb -40 to 60°C) equipment specified by the ATEX Directive. When connected to a suitable system the BA368C may be installed in:

Zone 0	explosive gas air mixture continuously present.
Zone 1	explosive gas air mixture likely to occur in normal operation.
Zone 2	explosive gas air mixture not likely to occur, and if it does will only exist for a short time.

Be used with gases in groups:

Group A	propane
Group B	ethylene
Group C	hydrogen

Having a temperature classification of:

T1	450°C
T2	300°C
T3	200°C
T4	135°C
T5	100°C

At an ambient temperature between -40 and +60°C.

**Note:** the guaranteed operating temperature range is -20 to +60°C

#### 1.4.6 Certification label Information

The certification label is fitted in a recess on the top of the enclosure.



#### WARNING installation in Zone 0

When installed in a Zone 0 potentially explosive atmosphere requiring apparatus of Category 1G, the instrument shall be installed such that even in the event of rare incidents, an ignition source due to impact or friction between the aluminium enclosure at the rear of the instrument mounting panel and iron/steel is excluded.



### 1.5.3 EMC

The BA368C complies with the requirements of the European EMC Directive 2004/108/EEC. For specified immunity all wiring should be in screened twisted pairs, with the screens earthed in the safe area.

To prevent circulating currents, cable screens should only be earthed at one point in the safe area.

### 1.6 PROGRAMMING

Detailed programming information is contained in each of the four function sections of this instruction manual.

#### 1.6.1 Security override link

To prevent accidental adjustment, or tampering, access to the programme menus may be protected by a four digit security code. If the security code is lost, access to the programmable functions can be obtained by moving the internal security link to the override position. The original security code can then be viewed by selecting 'COdE' from the main menu and pressing *P*.

To gain access to the security code link, remove the instrument terminal block(s) by gently pulling. Remove the six screws securing the rear panel and lift off the panel which will reveal the link – see Fig 1.4

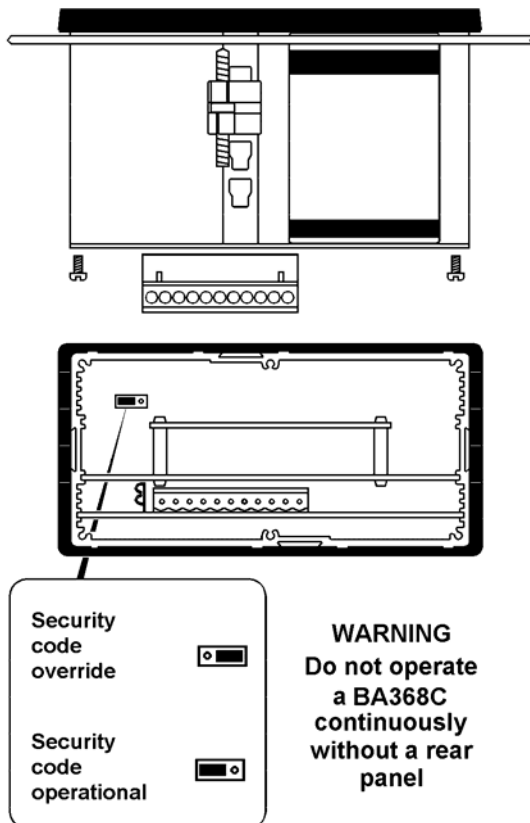

Fig 1.4 Location of security override link

### 1.7 SERVICING

A fault finding guide is contained in each section of this manual. If this does not reveal the cause of the problem, our sales department will be pleased to help you. Faulty BA368C instruments should be returned to BEKA associates, or to our agent in your area, for repair.

#### 1.7.1 Routine maintenance

The mechanical condition of the instrument should be regularly checked. The interval between inspections depends upon environmental conditions. We recommend that initially instruments should be inspected annually.

#### 1.7.2 Guarantee

Instruments which fail within the guarantee period should be returned to BEKA associates or our local agent. It is helpful if a brief description of the fault symptoms is provided.

### 1.8 CUSTOMER COMMENTS

BEKA associates is always pleased to receive comments from customers about our products and services. All communications are acknowledged and whenever possible, suggestions are implemented.

## 1.9 ACCESSORIES

### 1.9.1 Scale card

The BA368C has a window on the right hand side of the display to hold a card showing the units of measurements e.g. Litres, seconds, rpm. Instruments can be supplied with a printed scale card showing any units specified at the time of ordering. If a printed card is not requested, a blank card will be supplied.

Scale cards can easily be marked on-site as follows:

- Remove the rear terminal block(s) and the rear panel as shown in Fig 1.4
- Carefully pull the instrument assembly from the enclosure.
- Gently pull and then slide the blank scale card towards the display window until the card is free. Mark the card with the required legend and replace in the slot.
- Reassemble the instrument.

### 1.9.2 Tag number

The BA338C can be supplied with a thermally printed tag number on the rear panel. This tag number is not visible from the front of the instrument after installation.

### 1.9.3 Optional control outputs / alarm outputs

The BA368C can be supplied with two programmable solid state single pole outputs. The function of these outputs depends upon how the BA368C has been programmed i.e. as a counter, timer, tachometer or a clock. Full programming information is contained in each section of this manual

#### WARNING

**These control outputs should not be used for critical safety applications such as an emergency shut down system.**

**When the BA368C power supply is turned off or disconnected, both control outputs will open irrespective of how they have been programmed.**

Annunciators on the instrument display indicate the status of both control outputs.

### 1.9.3.1 Solid state output

Each output is a galvanically isolated single pole solid state switch as shown in Fig 1.5. The outputs are polarised and current will only flow in one direction. Terminals A1 and A3 should be connected to the positive side of the supply.

$$\begin{aligned} R_{on} &= 5\Omega + 0.6V \\ R_{off} &= \text{greater than } 180k \end{aligned}$$

**Note:** Because of the series protection diode some test meters may not detect a closed control output.

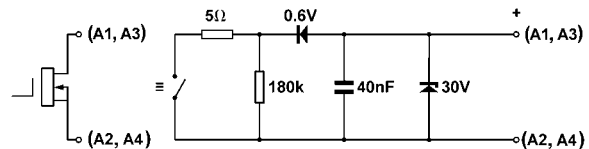

Fig 1.5 Equivalent circuit of each control output

### 1.9.3.2 Intrinsic safety

Both control outputs comply with the requirements for *simple apparatus* specified in Clause 5.5 of EN50020:1994. This allows them to be connected to any intrinsically safe circuit protected by a certified Zener barrier or galvanic isolator providing that the output parameters of each circuit do not exceed:

$$\begin{aligned} U_o &= 28V_c \\ I_o &= 200mA \text{ dc} \\ P_o &= 0.85W \end{aligned}$$

No system certificate has been issued for the BA368C switch contact outputs, as the system certificate for the circuit to which the alarms are connected remains valid.

The maximum equivalent capacitance and inductance of each BA368C control output is:

$$\begin{aligned} C_i &= 40nF \\ L_i &= 30\mu H \end{aligned}$$

To determine the maximum permissible cable parameters, the equivalent output parameters must be subtracted from the maximum cable capacitance and inductance specified by the system certificate of the circuit connected to each control output.



### 1.9.4 Optional pulse output

The BA368C can be supplied with an isolated solid state pulse output for use when the instrument is programmed as a counter. Section 2 of the manual explains the use and programming of this option

#### 1.9.4.1 Intrinsic safety

The pulse output is an optically isolated separate intrinsically safe circuit that has zero output safety parameters and therefore complies with the requirements for *simple apparatus*. This allows terminals P1 and P2 to be connected to any intrinsically safe circuit protected by a certified Zener barrier or galvanic isolator providing with output parameters not exceeding:

$$\begin{aligned} U_o &= 28V \\ I_o &= 100mA \text{ dc} \\ P_o &= 0.7W \end{aligned}$$

The maximum equivalent capacitance and inductance of the BA368C pulse output is:

$$\begin{aligned} C_i &= 20nF \\ L_i &= 20\mu H \end{aligned}$$

To determine the maximum permissible cable parameters, these figures must be subtracted from the maximum permitted cable capacitance and inductance specified by the system certificate of the circuit connected to the BA368C – usually a Zener barrier or galvanic isolator.

### 1.9.5 Optional 4/20mA output

The BA368C can be supplied with an optically isolated 4/20mA current sink which may be used when the instrument is programmed as a counter or as a tachometer. When the BA368C is programmed as a counter, the 4/20mA output may be proportional to pulse input rate or the total number of pulses. When programmed as a tachometer the current is proportional to rotational speed.

**Note:** The 4/20mA current output is not available when the BA368C is programmed as a timer or as a clock.

#### 1.9.5.1 Intrinsic safety

The 4/20mA output is an optically isolated separate intrinsically safe circuit which has zero output safety parameters and therefore complies with the requirements for *simple apparatus*. This allows terminals C1 and C2 to be connected to any intrinsically safe circuit protected by a certified Zener barrier or galvanic isolator providing the output parameters do not exceed:

$$\begin{aligned} U_o &= 28V \\ I_o &= 100mA \\ P_o &= 0.7W \end{aligned}$$

The maximum equivalent capacitance and inductance of the optional 4/20mA output at the terminals is:

$$\begin{aligned} C_i &= 2nF \\ L_i &= 8\mu H \end{aligned}$$

To determine the maximum permissible cable parameters, these figures must be subtracted from the maximum cable capacitance and inductance specified by the system certificate of the circuit connected to the BA368C 4/20mA output – usually a Zener barrier or galvanic isolator.

### 1.9.6 Optional display backlight

The BA368C can be supplied with LED backlighting to improve display contrast when the instrument is installed in a poorly illuminated area. The backlight is segregated from the measuring circuit and has been certified as a separate intrinsically safe circuit. System certificates for use with Zener barriers and galvanic isolators have therefore been issued.

The backlight must be powered from the safe area via a Zener barrier or a galvanic isolator as shown in Fig 1.6. Any certified Zener barrier may be used providing the output parameters do not exceed:

$$\begin{aligned} U_o &= 28V \\ I_o &= 159mA \\ P_o &= 0.8W \end{aligned}$$

The system certificate lists some of the galvanic isolators which may be used.

The maximum equivalent capacitance and inductance at the backlight terminals is:

$$\begin{aligned} C_i &= 40nF \\ L_i &= 30\mu H \end{aligned}$$

To determine the maximum permissible cable parameters, these figures should be subtracted from the maximum cable capacitance and inductance specified by the barrier or galvanic isolator powering the backlight. The system certificates specify maximum cable parameters for some devices.

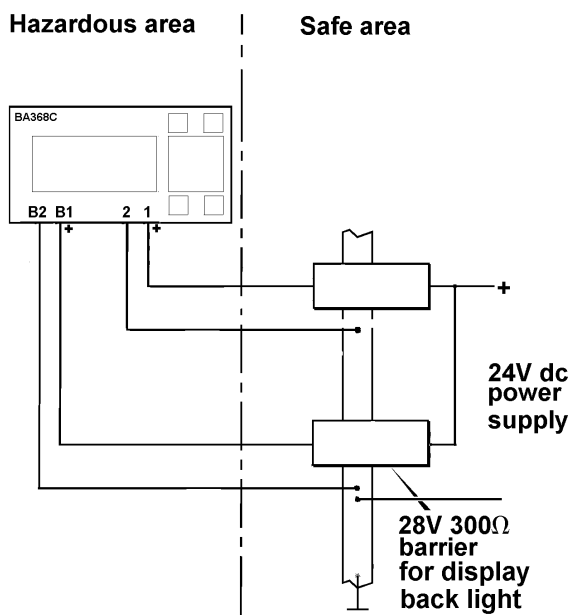

Fig 1.6 Backlight powered by Zener barrier

## Appendix 1

**FM approval for use in USA****A1.0 Factory Mutual Approval**

For installations in the USA, the BA368C and accessories have been approved intrinsically safe and nonincendive by FM Approvals, project identification 3022309. Copies of the Certificate of Compliance are available from the BEKA associates sales office and from the BEKA web site [www.beka.co.uk](http://www.beka.co.uk).

**A1.1 Intrinsic safety approval**

The BA368C is approved to the FM Class 3610 intrinsic safety standard. Installations must comply with BEKA associates Control Drawing CI330-33, which is attached to this Appendix, ANSI/ISA RP12.06.01 'Installation of Intrinsically Safe Systems for Hazardous (Classified) Locations' and with the National Electrical Code ANSI/NFPA70.

The BA368C has a T4 rating at ambient temperatures up to +60°C and may be used with the following gases:

<b>Intrinsic Safety</b>	
Division 1 or 2	
Class I	Group A & B Group C Group D
Zone 0, 1 or 2	
Class 1	Group IIC Group IIB Group IIA

The FM entity parameters are similar to the ATEX parameters. The intrinsically safe circuits shown in this manual may therefore be used for installations in the USA, providing the Zener barriers and galvanic isolators are FM Approved and comply with BEKA associates Control Drawing CI330-33.

**A1.2 Nonincendive approval**

The BA368C is Class 3611 nonincendive approved by Factory Mutual allowing it to be installed in Division 2 Classified Areas without the need for Zener barriers or galvanic isolators. Installations must comply with the BEKA associates Control Drawing CI330-35, which is attached to this Appendix, and with the National Electrical Code ANSI/NFPA70.

The BA368C has a T4 rating at ambient temperatures up to +60°C and may be used with the following gases:

<b>Nonincendive</b>	
Division 2	
Class I	Group A & B Group C Group D
Zone 2	
Class I	Group IIC Group IIB Group IIA





Iss.																																				
Date	22.04.2005																																			
Modification	First release																																			
Ckd.																																				
Appd.																																				
																																				
Iss.	1																																			
Date	22.04.2005																																			
Modification	First release																																			
Ckd.																																				
Appd.																																				
<p><b>Notes:</b></p> <ol style="list-style-type: none"> <li>The associated intrinsically safe barriers or galvanic isolators must be FM approved and the manufacturers' installation drawings must be followed when installing this equipment.</li> <li>The unclassified location equipment connected to the associated intrinsically safe barriers must not use or generate more than 250V rms or 250V dc.</li> <li>Installation should be in accordance with ANSI/ISA RP 12.06.01 "Installation of Intrinsically Safe Systems for Hazardous (Classified) Locations" and the National Electrical Code ANSI/NFPA 70.</li> <li>One single channel or one channel of a dual channel barrier or galvanic isolator with entity parameters complying with the following requirements: <table border="0" style="margin-left: 40px;"> <tr> <td>Uo or Vt</td> <td>equal to or less than</td> <td>Ui</td> </tr> <tr> <td>Io or It</td> <td>equal to or less than</td> <td>li</td> </tr> <tr> <td>Po</td> <td>equal to or less than</td> <td>Pi</td> </tr> <tr> <td>La</td> <td>equal to or greater than</td> <td>Lcable + Li</td> </tr> <tr> <td>Ca</td> <td>equal to or greater than</td> <td>Ccable + Ci</td> </tr> </table> </li> <li>Hazardous (classified) location equipment complying with the requirements of note 4 and the input parameters listed on Sheets 1 and 2 for Terminals 3 and 4, and 5 and 6, or simple apparatus.</li> <li>Simple apparatus or FM approved associated apparatus with contacts having entity parameters complying with the following requirements: <table border="0" style="margin-left: 40px;"> <tr> <td>Uo or Vt</td> <td>equal to or less than</td> <td>Ui</td> </tr> <tr> <td>Io or It</td> <td>equal to or less than</td> <td>li</td> </tr> <tr> <td>La</td> <td>equal to or greater than</td> <td>Lcable + Li</td> </tr> <tr> <td>Ca</td> <td>equal to or greater than</td> <td>Ccable + Ci</td> </tr> </table> </li> <li>To maintain NEMA 4X protection between the BA368C and the mounting panel: <p>Four panel mounting clips should be used</p> <p>Minimum panel thickness should be    2mm (0.08inches) Steel   3mm (0.12inches) Aluminium</p> <p>Outside panel finish should be smooth, free from particle inclusions, runs or build-up around cut-out.</p> <p>Panel cut-out should be                    66.2 x 136.0mm -0.0 +0.5   (2.60 x 5.35 inches -0.00 +0.02)</p> <p>Edges of panel cut-out should be deburred and clean</p> <p>Each panel mounting clip should be tightened to between: 20 and 22cNm (1.77 to 1.95 inLb)</p> <p style="text-align: right;">Cont.</p> </li> </ol>										Uo or Vt	equal to or less than	Ui	Io or It	equal to or less than	li	Po	equal to or less than	Pi	La	equal to or greater than	Lcable + Li	Ca	equal to or greater than	Ccable + Ci	Uo or Vt	equal to or less than	Ui	Io or It	equal to or less than	li	La	equal to or greater than	Lcable + Li	Ca	equal to or greater than	Ccable + Ci
Uo or Vt	equal to or less than	Ui																																		
Io or It	equal to or less than	li																																		
Po	equal to or less than	Pi																																		
La	equal to or greater than	Lcable + Li																																		
Ca	equal to or greater than	Ccable + Ci																																		
Uo or Vt	equal to or less than	Ui																																		
Io or It	equal to or less than	li																																		
La	equal to or greater than	Lcable + Li																																		
Ca	equal to or greater than	Ccable + Ci																																		
Title						Drawn	Checked	Scale																												
FM Approved Control Drawing for intrinsically safe BA364D & BA368C Counter, Timer, Tachometer & Clock						RC		NTS																												
						Drawing No.		CI330-33																												
						Sheet 3																														















## Section 2

### Use as a Counter

- 2.1 Description**
  - 2.1.1 Initialisation & loss of power
  - 2.1.2 Controls
  - 2.1.3 Displays
- 2.2 System certificates**
- 2.3 Use with Zener barriers**
  - 2.3.1 Power supply
  - 2.3.2 Input
  - 2.3.3 Resetting the total display
  - 2.3.4 Options
- 2.4 Use with galvanic isolators**
  - 2.4.1 Power supply
  - 2.4.2 Input
  - 2.4.3 Resetting the total display
  - 2.4.4 Options
- 2.5 Programming**
  - 2.5.1 Accessing programme functions
  - 2.5.2 Function of instrument
  - 2.5.3 Type of input
  - 2.5.4 Input count mode
  - 2.5.5 Counting edge
  - 2.5.6 Position of decimal point(s)
  - 2.5.7 Lower display
  - 2.5.8 Total scale factor
  - 2.5.9 Rate scale factor
  - 2.5.10 Rate display filter
  - 2.5.11 Timebase
  - 2.5.12 Direction of count
  - 2.5.13 Reset value
  - 2.5.14 Local reset
  - 2.5.15 Resetting grand total
  - 2.5.16 Security code
- 2.6 Optional Alarms**
  - 2.6.1 Programming and adjustment
  - 2.6.2 Alarm enable
  - 2.6.3 Type of alarm
  - 2.6.4 Setpoint adjustment
  - 2.6.5 Alarm function
  - 2.6.6 Alarm output status
  - 2.6.7 Hysteresis
  - 2.6.8 Alarm delay
  - 2.6.9 Alarm silence time
  - 2.6.10 Access setpoint
  - 2.6.11 Adjusting setpoints from display mode.
- 2.7 Optional 4/20mA output**
  - 2.7.1 Programming & adjustment
- 2.8 Optional pulse output**
  - 2.8.1 Programming & adjustment
- 2.9 Calibration example**
- 2.10 Maintenance**
  - 2.10.1 Fault finding during commissioning.
  - 2.10.2 Fault finding after commissioning.
- 2.11 Index for Counter section**

## 2.1 DESCRIPTION

When programmed as a counter the BA368C will accept pulses on one or both inputs and may be programmed to display:

Input A + Input B  
 Input A - Input B  
 Input A direction controlled by Input B  
 Quadrature input (Input A and Input B electrically 90° apart)

A separate six digit display may be activated to show the input pulse rate in engineering units per second, minute or per hour.

In addition to simple counting applications, the quadrature input allows direction of movement and position to be displayed.

The total display may be reset from the instrument front panel, or by closure of a remote contact. The instrument also maintains a grand total which can only be reset from within the programme menu.

An optional 4/20mA output current sink may be programmed to produce a linear output proportional to any positive part of the displayed total or displayed rate. For applications where the instrument is counting pulses on one or both inputs, (Input A + Input B) an optional retransmitted pulse output is also available.

Two optional alarm outputs may be programmed to operate on positive total or rate displays allowing simple batching applications to be performed.

### 2.1.1 Initialisation and loss of power

When power is applied to a BA368C counter, following initialisation the instrument will start functioning using the programmed parameters stored in permanent memory. If during operation the power supply is interrupted, all programme parameters, the displayed total and the grand total will be stored in permanent memory.

### 2.1.2 Controls

The BA368C counter is controlled and calibrated via four front panel push-button switches. In the display mode i.e. when the instrument is counting the switch functions are:

#### Description of Switch Functions

**E+Down** While these buttons are pushed the total display will show the eight digit grand total and the grand total annunciator will be activated.

**Down+Up** Resets the total display to zero or to the reset value when these two push-buttons are operated simultaneously for more than two seconds. Selectable function from programme menu. See section 2.5.14

**P+Down** While these buttons are pushed the instrument will display the firmware and version numbers plus the programmed function.

**Note:** When optional alarms are fitted, the BA368C may be programmed to provide direct access to the alarm setpoints from the display mode by operating the *P + Up* push-buttons. See section 2.6.10

### 2.1.3 Displays

The BA368C counter has two digital displays and associated annunciators.

**Total display** Shows total count since last reset on larger display which has a range of -9999999 to 99999999.

**Rate display** Shows rate on smaller lower display which has a range of -99999 to 999999. May be turned off – see 2.5.7

**Reset Annunciator** Activated while total display is being reset.

**Grand total Annunciator** Activated while grand total is being displayed.

**Alarm Annunciators** Activated when optional alarm is activated.

**2.2 SYSTEM CERTIFICATES**

In addition to the ATEX EC-Type Examination Certificate, ITS have issued two system certificates. One defines how the BA368C may be used with Zener barriers and the other with galvanic isolators.

Interface	Certificate No
Zener barriers	Ex01E2007
Galvanic isolators	Ex01E2008

This section interprets these system certificates and illustrates how to design counter systems with Zener barriers and galvanic isolators.

System certificates are Certificates of Conformity which are primarily issued for guidance in the UK. They do not form part of certification to the European ATEX Directive.

**2.3 USE WITH ZENER BARRIERS**

Zener barriers are the least expensive intrinsically safe interface between a safe and hazardous area. However, they do not provide isolation and require a high integrity earth connection that may be expensive to install. For a single BA368C counter it may be less expensive and complicated to use galvanic isolators when a high integrity earth connection is not already available.

Any certified Zener barriers may be used with the BA368C providing their output parameters do not exceed the input parameters of the terminals to which they are connected. Only one polarity of Zener barrier i.e. positive or negative, may be used with each instrument.

To assist with system design, the Zener barrier system certificate specifies the maximum output parameters of the Zener barriers that may be connected to the BA368C and defines the maximum cable parameters. Diode return barriers are identified by manufacturers type number, although alternatives may be used.

The basic system used for all BA368C hazardous area counter installations is shown in Fig 2.1 Intrinsic safety requirements are explained in section one of this manual which should be read before the system is designed.

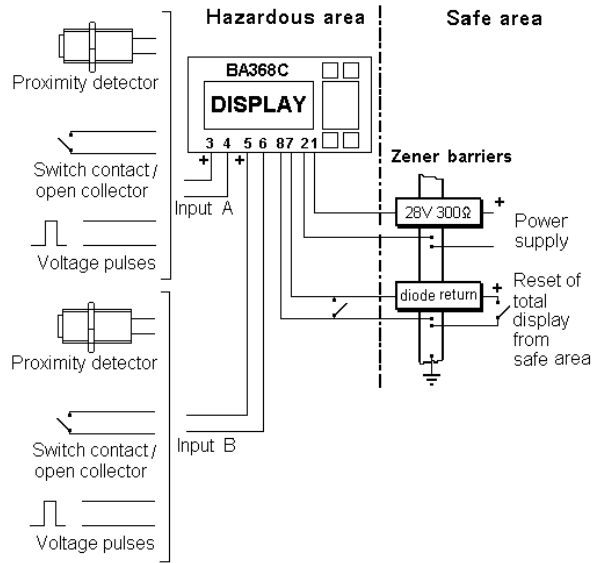

Fig 2.1 Counter installation using barriers

If the total display is reset from the instrument front panel, or from an external switch in the hazardous area, only the power supply Zener barrier is required.

**2.3.1 Power supply**

A BA368C is powered from the safe area via a positive polarity 28V 300Ω Zener barrier which will have an end-to-end resistance of about 340Ω. When operating as a counter with two proximity detector inputs, the BA368C consumes approximately 20mA and requires a minimum voltage of 10V between terminals 1 and 2. The supply voltage in the safe area must therefore be between 16.8V and the maximum working voltage of the Zener barrier – usually about 26V.

**2.3.2 Input**

When the BA368C is programmed as a counter both input A and input B are operational and may be independently programmed to operate with almost any pulse output transducer.

The following table shows the switching thresholds for the various transducers, plus the maximum operating frequency. For reliable counting the input signal must fall below the lower threshold and rise above the upper threshold.

Input	Switching thresholds		Freq. max
	Lower	Upper	
Switch	100Ω	1000Ω	100Hz
Proximity detector	1.2mA	2.1mA	5kHz
Open collector	2kΩ	10kΩ	5kHz
Magnetic pick-off	0mV	20mV peak	5kHz
Voltage pulse	1.0V	3.0V	5kHz

The intrinsic safety requirements are explained in section 1.4.3. Almost any mechanically or magnetically activated switch, intrinsically safe NAMUR 2-wire proximity detector or intrinsically safe voltage may be directly connected to the input terminals.

If the BA368C is located in a hazardous area but the transducer(s) is in a safe area, a Zener barrier is required to transfer the transducer output to the instrument. The system certificate defines barriers which may be used.

**2.3.3 Resetting the total display**

When terminals 7 & 8 are connected together the total display will be reset. To achieve reliable resetting the contacts must close for at least one second.

Resetting may be accomplished by any mechanically operated switch located in the hazardous area providing it can withstand a 500V rms insulation test to earth for one minute. No Zener barrier is required.

The BA368C may also be reset from within the safe area. Any switch may be used but a Zener barrier is required to transfer the contact closure into the hazardous area. A diode return barrier may be combined with the supply barrier so that only one dual channel device is required. The system certificate lists some of devices that may be used.

Fig 2.1 illustrates how the BA368C counter total display may be reset from both the safe and the hazardous area.

**2.3.4 Options**

When the BA368C is calibrated as a counter, optional alarms, a 4/20mA analogue output and a re-transmitted pulse output may be used. The intrinsic safety features of these options are described in section 1 of this manual and the counter applications in sections 2.6, 2.7 and 2.8.

**2.4 USE WITH GALVANIC ISOLATORS**

Galvanic isolators are probably the easiest intrinsically safe interface to use as they provide isolation and do not require a high integrity earth connection.

Any EEx ia IIC certified intrinsically safe galvanic isolators may be used with the BA368C providing the output parameters do not exceed the input parameters of the terminals to which they are connected.

To assist with system design, the galvanic isolator system certificate lists some of the isolators that may be used and defines the maximum permitted cable parameters.

Fig 2.2 illustrates the basic circuit that is used for all BA368C counter installations protected by galvanic isolators. Intrinsic safety requirements are explained in section one of this manual which should be read before the system is designed.

If the total display is reset from the instrument front panel, or from an external switch in the hazardous area, only the power supply galvanic isolator is required.

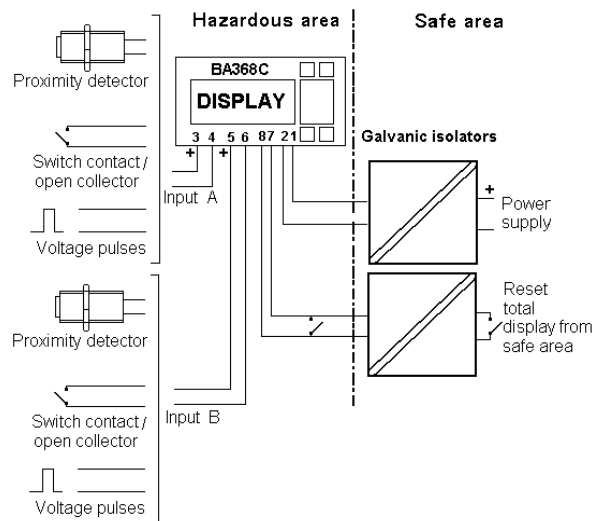

Fig 2.2 Basic counter circuit using isolators



### 2.4.1 Power supply

The BA368C galvanic isolator system certificate lists a wide range of certified galvanic isolators that may be used to power the instrument. If using the entity concept to select an isolator, in addition to matching the safety parameters, the isolator must be capable of supplying 10V dc minimum at 20mA to the BA368C.

### 2.4.2 Input

When the BA368C is programmed as a counter both input A and input B are operational. These inputs may be independently programmed to operate with almost any pulse output transducer.

The following table shows the switching thresholds for the various transducers, plus the maximum operating frequency. For reliable counting the input signal must fall below the lower threshold and rise above the upper threshold.

Input	Switching thresholds		Freq. max
	Lower	Upper	
Switch	100 $\Omega$	1000 $\Omega$	100Hz
Proximity detector	1.2mA	2.1mA	5kHz
Open collector	2k $\Omega$	10k $\Omega$	5kHz
Magnetic pick-off	0mV	20mV peak	5kHz
Voltage pulse	1.0V	3.0V	5kHz

The intrinsic safety requirements are explained in section 1.4.3. Almost any mechanically or magnetically activated switch, or intrinsically safe NAMUR 2-wire proximity detector may be directly connected to the input terminals.

If the BA368C is located in a hazardous area but the transducers are in the safe area, a galvanic isolator is required to transfer the transducer output(s) to the instrument. The system certificate defines some of the devices which may be used.

### 2.4.3 Resetting the total display

When terminals 7 & 8 are connected together the total display will be reset. To achieve reliable resetting the contacts must close for at least one second.

Resetting may be accomplished by any mechanically operated switch located in the hazardous area providing it can withstand a 500V rms insulation test to earth for one minute. No galvanic isolator is required.

The BA368C may also be reset from within the safe area. Any switch may be used, but a galvanic isolator or intrinsically safe relay is required to transfer the contact closure into the hazardous area. See system certificate for a list of some devices that may be used. Fig 2.2 illustrates how the BA368C may be reset from both the safe and the hazardous area.

### 2.4.4 Options

When the BA368C is calibrated as a counter, optional alarms, a 4/20mA analogue output and a re-transmitted pulse output may be used. The intrinsic safety features of these options are described in section 1 of this manual and the counter applications in sections 2.6, 2.7 and 2.8.

## 2.5 PROGRAMMING

Throughout this manual push-buttons are shown in italics e.g. *P* or *Up* push-button, and legends displayed by the instrument are shown within inverted commas e.g. 'SCALE-t' and 'COdE'.

### 2.5.1 Accessing programme functions

Access to the programme menu is obtained by operating the *P* and *E* push-buttons simultaneously. If the BA368C is not protected by a security code the first parameter 'Function' will be displayed. If a security code other than the default code 0000 has already been entered, the instrument will display 'COdE'. Press *P* to clear this prompt and enter the security code for the instrument using the *Up* or *Down* push-button to adjust each digit, and the *P* push-button to move control to the next digit. If the correct code has been entered pressing *E* will cause the first parameter 'Function' to be displayed. If an incorrect code is entered, or a push-button is not operated within ten seconds, the instrument will automatically return to the display mode.

Once within the main programme menu the required parameter can be reached by scrolling through the menu using the *Up* and *Down* push-buttons as shown by the counter programme structure shown in Fig 2.3.

This section summarises all the counter programmable parameters excluding the optional alarms, 4/20mA analogue output and the re-transmitted pulse output. When read in conjunction with Fig 2.3 it provides a quick aid for programming the instrument. If more detail is required, each section contains a reference to a full description of the function.

Programming details for the optional alarms, analogue 4/20mA output and the re-transmitted pulse output are contained in sections 2.6, 2.7 and 2.8

## SUMMARY

<u>Display</u>	<u>Description of function</u>
'Function'	<b>Function of instrument</b> Enables the BA368C to be conditioned as a counter, timer, tachometer or clock. After making the selection 'SurE' has to be entered to confirm the instruction Select 'CountEr' to enable the counter functions. See section 2.5.2
'InPut A'	<b>Type of input</b> Conditions input A to work with one of five types of transducer: 'UOLtS' Voltage pulse 'COIL' Magnetic pick-off 'Pr.dEt' NAMUR proximity detector. 'COntACT' Switch contact 'OP.COL' Open collector See section 2.5.3
'InPut b'	<b>Type of input</b> As above but for input B See section 2.5.3
'Count'	<b>Input count mode</b> Defines the arithmetic relationship of the two pulse inputs A and B: 'A : b' A plus B 'A : -b' A minus B 'A Con b' A, direction controlled by B 'A rEL b' Quadrature A and B See section 2.5.4
'Cnt. EdGE'	<b>Counting edge</b> Defines the edge on which both inputs count. See section 2.5.5
'd.P.'	<b>Position of decimal points</b> Defines the position of the decimal points in both displays. See section 2.5.6
'dISPLAY.2'	<b>Lower display (rate)</b> Turns the lower six digit display, which shows the rate, on or off. See section 2.5.7

<u>Display</u>	<u>Description of function</u>						
'SCALE-t'	<p><b>Total scale factor</b>            Defines the arithmetic relationship between the number of input pulses and the total display. Dividing factor adjustable between 0.001 and 99999999.            See section 2.5.8</p>						
'SCALE-r'	<p><b>Rate scale factor</b>            Defines the arithmetic relationship between the pulse input frequency and the rate display. Dividing factor adjustable between 0.001 and 99999999.            See section 2.5.9</p>						
'FILtEr'	<p><b>Rate display filter</b>            Adjustable digital filter to reduce noise on the rate display. Two parameters each adjustable between 0 and 9.            See section 2.5.10</p>						
't-bASE'	<p><b>Timebase</b>            Selectable multiplier to display rate in units per second, per minute or per hour.            Select:</p> <table border="0"> <tr> <td>tb-1</td> <td>rate / second</td> </tr> <tr> <td>tb-60</td> <td>rate / minute</td> </tr> <tr> <td>tb-3600</td> <td>rate / hour</td> </tr> </table> <p>See section 2.5.11</p>	tb-1	rate / second	tb-60	rate / minute	tb-3600	rate / hour
tb-1	rate / second						
tb-60	rate / minute						
tb-3600	rate / hour						
'uP or dn'	<p><b>Direction of count</b>            Determines whether pulses at inputs A and B increment or decrement the total display.            See section 2.5.12</p>						

<u>Display</u>	<u>Description of function</u>
'rSET UAL'	<p><b>Reset value</b>            Defines a pre-set number to which the display will be set when the BA368C is locally or remotely reset. Allows the instrument to count down from a preset number.            See section 2.5.13</p>
'LOC-rSET'	<p><b>Local reset of total display</b>            When turned 'On' the total display may be reset from the display mode by simultaneously operating the <i>Up</i> and <i>Down</i> push-buttons for at least two seconds.            See section 2.5.14</p>
'CLr.Gtot'	<p><b>Resetting grand total</b>            This function resets the grand total to zero when 'CLr YES' is selected, and 'SurE' is entered to confirm the instruction.  <b>Note:</b> Once cleared, a grand total can not be recovered.            See section 2.5.15</p>
'COdE'	<p><b>Security code</b>            Defines a four digit numeric code which must be entered to gain access to the programmable functions. Default code 0000 disables the security function and allows unrestricted access to all programmable functions.            See section 2.5.16</p>

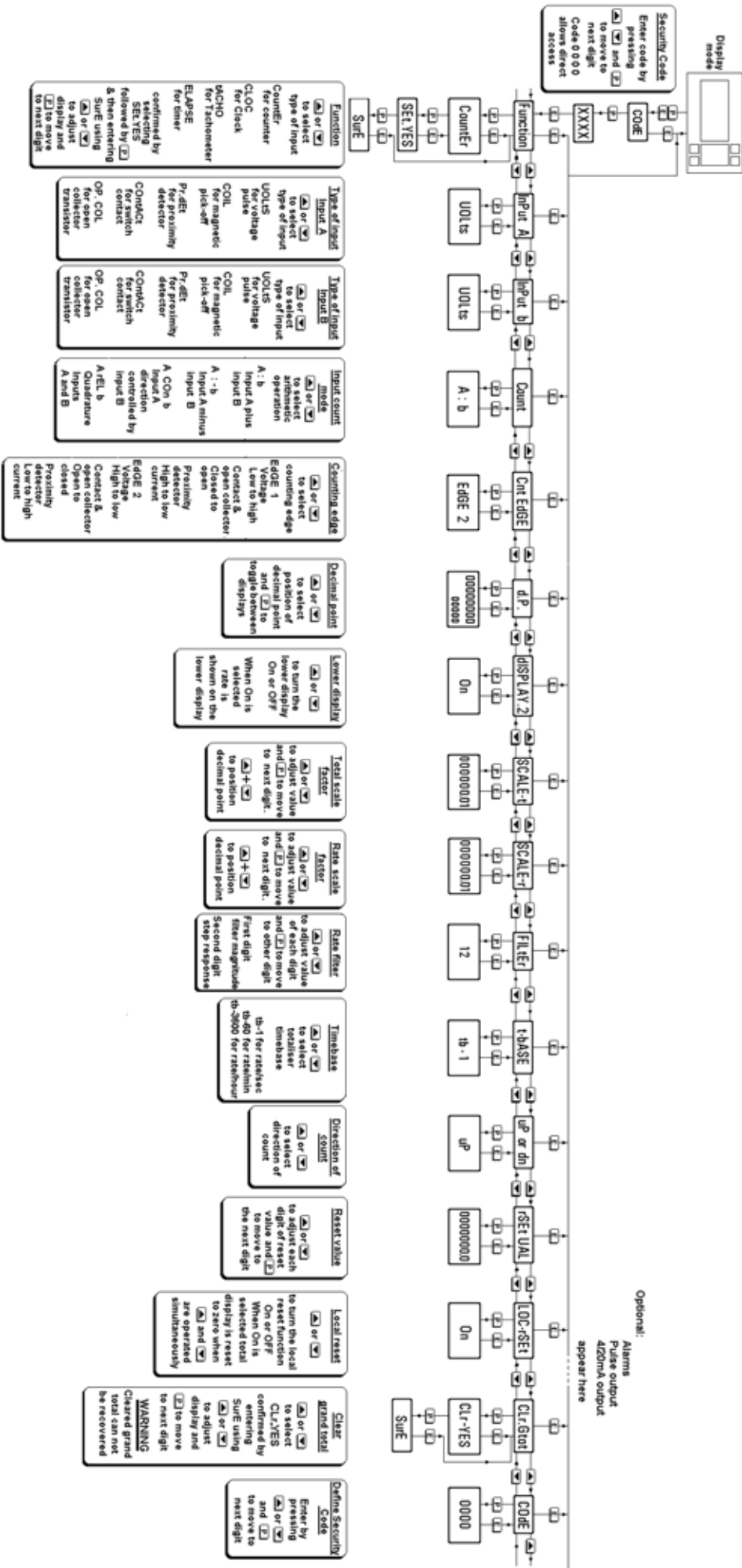

Fig 2.3 Counter programme structure

**22.5.2 Function of instrument: 'Function'**

This is the first parameter in the programme menu which conditions the instrument as a counter, timer, tachometer or as a clock.

**CAUTION**

**This function must be entered before any of the other parameters are programmed. It is protected by a password to prevent accidental changes.**

To define the instrument function select 'Function' from the main menu and press *P* which will reveal the existing setting. Pressing the *Up* or *Down* button will scroll through the four options:

Display	Instrument function
'CountEr'	Counter
'CLOC'	Clock
'tACHO'	Tachometer
'ELAPSE'	Timer

With 'CountEr' selected, press *P* which will change the display to 'Set.nO'. To proceed press *Up* or *Down* which will change this prompt to 'Set.YES' and then confirm the function change by pressing *P* which will result in a 'Set 0000'. Using the *Up* and *Down* buttons and the *P* button to move to the next digit, enter the password 'SurE'. Note 'S' is entered as '5'. Finally, pressing *E* will execute the function change to a counter and return the display to the 'Function' prompt in the main menu.

**2.5.3 Type of input: 'InPut A' and 'InPut b'**

To define an input type select 'InPut A' from the menu and press *P* which will reveal the current input type. Pressing the *Up* or *Down* button will scroll through the five options:

'UOLts'	Voltage input Threshold 1V and 3V 5kHz max.
'COIL'	Low voltage Threshold 20mV peak 5kHz max.
'Pr.dEt'	NAMUR proximity detector Threshold 1.2 and 2.1mA 5kHz max.
'COntACT'	Switch contact Threshold 100 and 1000Ω 100Hz max
'OP.COL'	Open collector Threshold 2kΩ and 10kΩ 5kHz max.

When the required type of input has been selected press *E* to enter the selection and return to the 'InPut A or b' prompt in the main menu. To count reliably, the input signal must fall below the lower switching threshold and rise above the higher switching threshold.

**2.5.4 Input count mode: 'Count'**

This parameter defines the arithmetic relationship between the two inputs A and B. The following four modes may be selected

Display	Input count mode						
'A : b'	Pulses on input A added to pulses on input B						
'A : -b'	Pulses on input B subtracted from pulses on input A						
'A Con b'	Input B controls count direction of input A. <table border="1"> <thead> <tr> <th>Input B</th> <th>Input A</th> </tr> </thead> <tbody> <tr> <td>Low</td> <td>Up counter</td> </tr> <tr> <td>High</td> <td>Down counter</td> </tr> </tbody> </table>	Input B	Input A	Low	Up counter	High	Down counter
Input B	Input A						
Low	Up counter						
High	Down counter						
'A rEL b'	Quadrature input with transducers electrically 90° apart. <b>Note:</b> Maximum input frequency 2kHz.						

COUNTER

The diagrams below show the voltage waveforms at the two inputs and the resulting display when the BA368C is programmed to count on a rising edge.

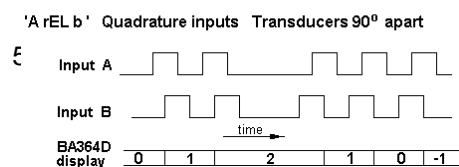
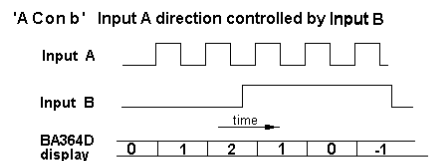
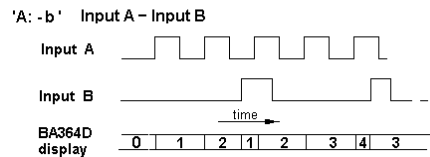
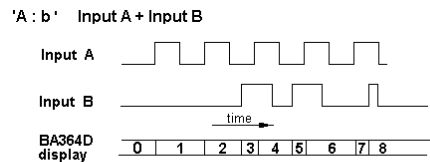

To achieve reliable counting from a quadrature encoder the two input signals do not require equal marks and spaces, but input A must not change state for 100µS before or after input B as shown in timing diagram below.

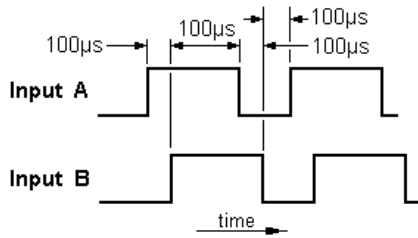

### 2.5.5 Counting edge 'Cnt. EdGE'

This function allows the edge on which a count occurs to be selected. It applies to input A for all counting modes except quadrature ('A rEL b') and to input B for all modes except for A controlled by B ('A Con b').

To check or change the edge on which counting occurs select 'Cnt EdGE' from the menu and press *P* which will reveal 'EdGE 1' or 'EdGE 2'. If required press the *Up* or *Down* button to change the setting, followed by the *E* button to return to the main menu.

#### EdGE 1

Type of input	Counting edge
Voltage	Low to high
Switch contact	Closed to open
Open collector	Closed to open
Proximity detector	High to low current

#### EdGE 2

Type of input	Counting edge
Voltage	High to low
Switch contact	Open to closed
Open collector	Open to closed
Proximity detector	Low to high current

### 2.5.6 Position of the decimal point(s): 'd.P.'

The BA368C total display has eight digits. The decimal point may be positioned between any of the seven least significant digits, or it may be omitted.

To adjust the position of the decimal point select 'd.P.' from the main menu and press *P*. This will activate the display with one digit plus the following decimal point flashing. If only the least significant digit is flashing the decimal point will be omitted. The position of the decimal point can be moved by pressing the *Up* or *Down* push-button.

Similarly, a decimal point may be positioned between any of the five least significant digits on the lower rate display, or may be omitted. Pressing the *P* push-button will transfer control to the lower display.

When the decimal point(s) have been positioned as required press *E* to return to the main menu.

**Note:** It is only necessary to position the decimal point in the lower display if it is activated, see 2.5.7, or a rate alarm or a 4/20mA rate output is required.

### 2.5.7 Lower display: 'DISPLAY.2'

This function turns the lower rate display on or off. When turned off the BA368C will display just the total number of pulses, when turned on it will display the total number of pulses and the pulse rate simultaneously. To check the status of the lower display select 'DISPLAY.2' from the menu and press *P* which will reveal if the function is 'On' or 'OFF'. If required press the *Up* or *Down* button to change the setting, followed by the *E* button to return to the main menu.

**Note:** Providing the rate scale factor, timebase and displayed decimal point have been programmed, all the rate functions will operate irrespective of whether the lower display is turned on or off.

### 2.5.8 Total scale factor: 'SCALE-t'

This factor defines the arithmetic relationship between the number of input pulses and the total display. SCALE-t is a dividing factor that may be adjusted between 0.001 and 99999999.

e.g. If the counter is required to increment the display one count when 120 pulses have been received:

$$\text{SCALE-t} = \frac{\text{Number of input pulses}}{\text{Required display}}$$

$$= \frac{120}{1}$$

$$\text{SCALE-t} = 120$$

To check or change the scale factor select 'SCALE-t' from the main menu and press *P* to reveal the existing setting, one digit will be flashing. The value of the flashing digit can be changed by pressing the *Up* or *Down* buttons. When this digit is correct pressing *P* will transfer control to the next digit.

To position the decimal point in the scaling factor, move the flashing digit to the left hand side of the required decimal point position and simultaneously press the *Up* and *Down* buttons.

When the required total scale factor has been entered, press *E* to return to the main menu.

### 2.5.9 Rate scale factor: 'SCALE-r'

'SCALE-r' is a dividing factor which may be adjusted between 0.001 and 99999999. Together with the instrument timebase, 'SCALE-r' defines the arithmetic relationship between the pulse input frequency and the rate display.

e.g. If the BA368C is required to display a rate of 1 unit per hour when 3 pulses are received per second:

$$\text{SCALE-r} = \frac{\text{(Number of input pulses/s)} \times \text{(Timebase)}}{\text{Required display / unit of time}}$$

where timebase equals

1	for rate display / second
60	for rate display / minute
3600	for rate display / hour

$$\text{SCALE-r} = \frac{(3 \text{ pulses / s}) \times (3600)}{1 \text{ per hour}}$$

$$\text{SCALE-r} = 10800$$

To check or change the rate scaling factor select 'SCALE-r' from the main menu and press *P* to reveal the existing setting, one digit will be flashing. The value of the flashing digit can be changed by pressing the *Up* or *Down* button. When this digit is correct pressing *P* will transfer control to the next digit.

To position the decimal point in the rate scale factor, move the flashing digit to the left hand side of the required decimal point position and simultaneously press the *Up* and *Down* buttons.

When the required rate scale factor has been entered, press *E* to store the number and return to the main menu.

### 2.5.10 Rate display filter: 'FILtEr'

This digital filter has two independent adjustable parameters enabling the rate display frequency response to be tailored for optimum performance.

The filter parameters are controlled by a two digit number. The first digit defines the amount of filtering applied to the display as shown below.

First digit	Filter time constant seconds
0X	0
1X	1.3
2X	4.3
3X	6.5
4X	8.7
5X	11.3
6X	15.7
7X	20.9
8X	25.2
9X	31.5

The second digit defines the deviation from the displayed rate at which the filter will be overridden and the rate display will move rapidly to the new value.

Second digit	Magnitude of step change which will produce a rapid response
X0	Off
X1	1%
X2	2%
X3	4%
X4	8%
X5	12%
X6	16%
X7	24%
X8	32%
X9	64%

By careful adjustment of the two parameters a stable display with an acceptable step input response can be obtained for most applications.

During commissioning it is recommended that initially the second digit is set to 0 (off) and the first digit is adjusted to provide acceptable rate display stability. The second digit should then be increased until the selected step size is greater than the noise on the display signal, at which setting the rate display will again become stable. These will be the optimum filter parameters for acceptable rate display stability and a fast response to a large rate signal change.

To check or change the filter select 'FILtEr' from the main menu and press *P* to reveal the current settings. Pressing the *Up* or *Down* button will change the flashing digit and *P* will transfer control to the second digit. While making adjustments the filtered rate display is shown on the lower display so that stability can be assessed. When set as required, press the *E* button to enter the revised parameters and return to the main menu.

### 2.5.11 Timebase: 't-bASE'

This function multiplies the rate display by 1, 60 or 3,600 to show rate per second, per minute or per hour.

To check or change the timebase, select 't-bASE' from the main menu and press *P* which will reveal the current setting. Pressing the *Up* or *Down* button will scroll through the three options:

Display	Units
tb-1	for rate / second
tb-60	for rate / minute
tb-3600	for rate / hour

When the required timebase is displayed press *E* to enter the selection and return to the main menu.

### 2.5.12 Direction of count: 'uP or dn'

This parameter defines whether input pulses increment or decrement the display. i.e. whether Input A of the BA368C is an up-counter or a down-counter.

To check or change the count direction select 'uP or dn' from the menu and press *P* which will reveal the present setting. 'uP' indicates that the instrument is an up-counter and 'dn' that it is a down-counter. Pressing the *Up* or *Down* buttons will toggle the display between the two settings. When set as required, press the *E* button to enter the setting and return to the main menu.

### 2.5.13 Reset value: 'rSEt UAL'

This function defines the value to which the display is reset when the local or remote reset is operated. This allows the BA368C to be used as a pre-set down counter.

When the instrument is programmed as an up-counter, 'rSEt UAL' is normally set to zero.

To check or change the reset value select 'rSEt UAL' from the main menu and press *P* which will reveal the current setting. The value of the flashing digit may be changed by pressing the *Up* or *Down* buttons. When this digit is correct pressing *P* will transfer control to the next digit.

When the reset value is set as required, press the *E* button to enter the revised number and return to the main programme menu.

### 2.5.14 Local reset of total display: 'LOC- rSEt'

This function allows the local reset of the total display to be turned on or off. When turned on, operating the *Up* and *Down* push-buttons simultaneously for more than two seconds in the display mode will reset the total display to the reset value 'rSEt.UAL'. See 2.5.13

To check the status of the local reset function select 'LOC-rSEt' from the menu and press *P* which will reveal if the function is 'On' or 'OFF'. If required press the *Up* or *Down* button to change the setting, followed by the *E* button to return to the main menu.

The total display may also be reset to zero remotely by connecting terminals 7 and 8 together. See Figs 2.1 and 2.2

### 2.5.15 Resetting grand total: 'CLr. Gtot'

The grand total is a separate eight digit counter which duplicates the total display, but is not cleared when the total display is reset.

The grand total may be viewed when the instrument is in the display mode by operating the *E* and *Down* push-buttons simultaneously.

The grand total can only be reset to zero from the 'CLr. Gtot' function in the main programme menu. To zero the grand total select 'CLr. Gtot' and press *P* which will cause the instrument to display 'Clr. no' with 'no' flashing. Continuously press the *Up* or *Down* push-buttons until 'CLr. YES' is displayed and then press *P* which will result in a 'CLr. 0000' prompt with one digit flashing. Using the *Up*, and *Down* buttons and the *P* button to move to the next digit, confirm the request by entering the password 'SurE'. Note 'S' is entered as '5'. Pressing *E* will then reset the grand total counter to zero and return the instrument to the 'CLr. Gtot' prompt in the main menu.

#### WARNING

**After resetting the grand total to zero the old grand total can not be recovered.**

### 2.5.16 Security code: 'COdE'

The calibration and conditioning of the BA368C may be protected by a four digit security code which must be entered before access to the programme menu is allowed. New instruments are programmed with the default security code 0000 that allows unrestricted access to all programming functions without entering a security code.

To enter a new security code select 'COdE' from the menu and press *P* which will cause the instrument to display the current security code. Each digit of the code can be changed using the *Up* and *Down* push-buttons, and the *P* button to move to the next digit. When the required code has been entered press *E* to return to the main menu. The revised security code will be activated when the instrument is returned to the display mode.

If the security code is lost, access to the programmable functions can be obtained by moving the internal security link to the override position as shown in section 1.6.1. The original security code can then be viewed by selecting 'COdE' from the main menu and pressing *P*.



## 2.6 OPTIONAL ALARMS

### 2.6.1 Programming and adjustment

The BA368C can be supplied with two solid state single pole alarm outputs which may be independently programmed as high or low, total or rate alarms with normally open or normally closed outputs. See section 1.9.3 for details.

For simplicity Fig 2.4 only shows the programmable functions for one alarm output. The second output is identical.

The following table summarises each of the alarm programme functions and includes a cross reference to more detailed information. Again only the functions on alarm AL1 are listed.

#### Summary of programmable alarm functions

<u>Display</u>	<u>Description of function</u>
'EnbL'	<b>Alarm enable</b> Enables or disables the alarm function without changing the alarm parameters. See section 2.6.2
'tYPE'	<b>Type of alarm</b> Defines whether the alarms operate on the total or the rate display. See section 2.6.3
'SPt1' or 'SPr1'	<b>Alarm setpoint 1</b> Adjusts the alarm setpoint. The alarm is activated when the display equals the setpoint. See section 2.6.4
'HI.LO'	<b>Alarm function</b> Defines whether the alarm has a high or low function See section 2.6.5
'no.nc'	<b>Normally open or normally closed output</b> Determines whether the single pole alarm output is open or closed in the non-alarm condition. See section 2.6.6
'HStr'	<b>Hysteresis</b> Adjusts the alarm hysteresis. Only available for rate alarms. See section 2.6.7

<u>Display</u>	<u>Description of function</u>
'dELA'	<b>Alarm delay time</b> Adjusts the delay between the display equalling the setpoint and the alarm output being activated. See section 2.6.8
'SIL'	<b>Alarm silence time</b> Defines the time that the alarm output remains in the non-alarm condition following acceptance of an alarm. See section 2.6.9
'AcSP'	<b>Access setpoint</b> Sub-menu that enables direct access to the alarm setpoints from the display mode and defines a separate security code. See section 2.6.10



### 2.6.2 Alarm enable: 'EnbL'

This function allows the alarm output to be enabled or disabled without altering any other parameters. To check or change the function select 'EnbL' from the alarm menu and press *P* which will reveal the current setting. The function can be changed by pressing the *Up* or *Down* button followed by the *E* button to return to the alarm menu.

### 2.6.3 Type of alarm: 'tYPE'

The 'tYPE' function conditions the alarm to operate from the total or rate display.

To check or change the type of alarm, select 'tYPE' from the alarm menu and press *P* which will reveal the current setting, 'tOtAL' or 'rAtE'. The function can be changed by pressing the *Up* or *Down* button followed by the *E* button to return to the alarm menu.

**Note:** When 'tYPE' is changed, the alarm parameters are automatically set to the default values and the alarm is disabled. It must therefore be reprogrammed before use.

### 2.6.4 Setpoint adjustment: 'SPt1' or SPPr1'

The setpoint, which is displayed in the units and format selected when the instrument was programmed, may be positioned anywhere in the positive instrument display range.

**Note:** The setpoints can not be negative.

To adjust the setpoint of alarm 1 select 'SPt1' or 'SPPr1' from the main menu. SPt1 is displayed when a total alarm has been selected and SPPr1 when a rate alarm has been selected. Pressing *P* will reveal the existing setpoint value with one digit flashing. Each digit may be adjusted using the *Up* and *Down* push-buttons and the *P* button will transfer control to the next digit. When set as required, pressing *E* will return the display to the alarm menu.

### 2.6.5 Alarm function: 'HI.LO'

Each alarm may be conditioned as a high or low alarm. To check or change the alarm function select 'HI.LO' from the alarm menu and press *P* to reveal the current setting. The function can be changed by pressing the *Up* or *Down* buttons followed by the *E* button to return to the alarm menu.

### 2.6.6 Alarm output status: no.nc

The alarm output may be open or closed in the non-alarm condition. When the BA368C power supply is turned off or disconnected, both the alarm outputs will open irrespective of whether normally open or normally closed outputs have been selected. Therefore an open output should be the alarm condition for fail-safe operation.

To check the alarm output status select 'no.nc' from the alarm menu and press *P* to reveal the current setting. The function can be changed by pressing the *Up* or *Down* button followed by the *E* button to return to the alarm menu.

### 2.6.7 Hysteresis: 'HStr'

Hysteresis is only available when the alarm has been conditioned as a rate alarm. During programming, hysteresis is shown in the units that the instrument has been calibrated to display.

To adjust the hysteresis, select 'HStr' from the alarm menu and press *P* to reveal the existing figure. Each digit can be adjusted using the *Up* and *Down* push-buttons. The *P* button transfers control to the next digit. When the required hysteresis has been entered, press *E* to return to the alarm menu.

e.g. When calibrated to display frequency with a high alarm at 100Hz and hysteresis of 5Hz, the alarm will perform as follows:

High alarm will be activated when frequency (rate) equals or exceeds 100Hz, but will not reset until the frequency falls below 95Hz.

### 2.6.8 Alarm delay: 'dELA'

The alarm output may be delayed for a fixed time following the alarm condition occurring. The delay can be programmed in 1 second increments up to 3600 seconds. If a delay is not required zero should be entered. To adjust the delay select 'dELA' from the alarm menu and press *P* which will reveal the existing delay time. Each digit of the delay can be adjusted using the *Up* and *Down* push-buttons, and the *P* button to move to the next digit. When the required delay has been entered, press *E* to return to the alarm menu.

The front panel alarm annunciator will start flashing immediately an alarm occurs and continue for the delay time after which the alarm output will be activated.

### 2.6.9 Alarm silence time: 'SIL'

This is primarily intended for use in small installations where the alarm output directly operates an annunciator such as a sounder. When the alarm silence time is set to any figure other than zero, the *P* push-button becomes an alarm accept button.

After an alarm has occurred, operating the *P* button will cause the alarm output to revert to the non-alarm condition for the programmed alarm silence time. When an alarm is silenced the BA368C front panel alarm annunciator will flash until the silence time expires.

To adjust the silence time select 'SIL' from the alarm menu and press *P* which will reveal the existing time. The time may be adjusted to between 0 and 3600 seconds in 1 second increments. Each digit can be adjusted using the *Up* and *Down* push-buttons, and the *P* button transfers control to the next digit. When the required time has been entered press *E* to return to the alarm menu.

### 2.6.10 Access Setpoint: 'AcSP'

This function activates a separate menu that provides direct access to the alarm setpoints when the instrument is in the display mode i.e. counting. See section 2.6.11 for a full description. An operator may therefore adjust the setpoints without having access to the programme and alarm menus. Further protection may be provided by a separate security code.

This direct access menu is enabled and a separate security code entered from the 'AcSP' function in the main programme menu as shown in Fig 2.4 To change the menu parameters select 'AcSP' from the programme menu and press *P*. This will display the enable prompt 'EnbL'.

Pressing *P* again will reveal if the direct access menu is 'On' or 'OFF'. The *Up* or *Down* buttons will toggle the display between the two conditions.

If 'OFF' is selected, the operator will not have access to the setpoints from the display mode. Return to the 'AcSP' prompt in the main menu by pressing *E* twice.

If 'On' is selected, the operator will have direct access to the alarm setpoints from the display mode via a separate optional security code. To define this four digit numeric code press *E* to return to the 'EnbL' prompt followed by the *Up* or *Down* button to select the access code prompt 'AcCd'. Pressing *P* will then reveal the current security code with one digit flashing. The code may be changed by operating the *Up* or *Down* push-buttons and pressing the *P* button to transfer control to the next digit. Finally press *E* twice to enter the new security code and return to the 'AcSP' prompt in the programme menu.

Entering code 0000 will disable the security code allowing direct access to the setpoints in the display mode by pressing the *P* and *Up* buttons simultaneously.

New instruments with alarms are supplied with the security code set to 0000

### 2.6.11 Adjusting alarm setpoints from the display mode

Access to the two alarm setpoints from the instrument display mode is obtained by operating the *P* and *Up* push-buttons simultaneously as shown in Fig 2.5. If the setpoints are not protected by a security code the alarm setpoint prompt 'SPt1' or 'SPr1' will be displayed, depending upon whether alarm 1 has been programmed as a total or rate alarm. If the setpoints are protected by a security code, 'COde' will be displayed first. Pressing *P* again will enable the alarm security code to be entered digit by digit using the *Up* and *Down* buttons to change the flashing digit and the *P* push-button to move control to the next digit. If the correct code is entered pressing *E* will then cause alarm setpoint prompt 'SPx1' to be displayed. If an incorrect security code is entered, or a button is not pressed within ten seconds, the instrument will automatically return to the display mode.

Once within the menu pressing the *Up* or *Down* buttons will toggle the display between the two alarm setpoint prompts 'SPx1' and 'SPx2'.

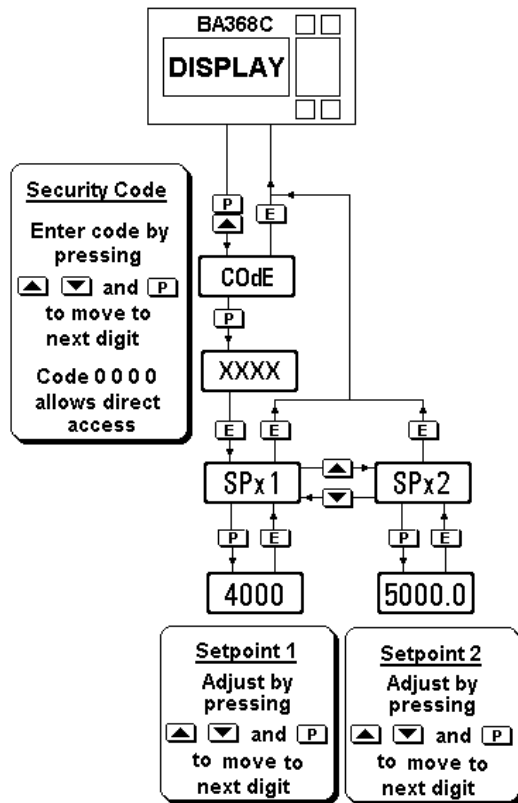

Fig 2.5 Setpoint adjustment from the display mode

To adjust an alarm setpoint, select 'SPx1' or 'SPx2' and press *P* which will reveal the current setting. Each digit of the setpoint may be adjusted using the *Up* and *Down* push-buttons, and the *P* button to move control to the next digit. When the required setpoint has been entered, pressing *E* will return the display to the 'SPx1' or 'SPx2' prompt from which the other setpoint may be selected, or the instrument may be returned to the display mode by pressing *E* again.

**Note:** Direct access to the alarm and control output setpoints is only available when the menu is enabled - see section 2.6.10

## 2.7 OPTIONAL 4/20mA OUTPUT

The BA368C can be supplied with an optional 4/20mA output which may be programmed to produce an analogue output proportional to the whole or part of the total or rate display. See section 1.9.5.1 for intrinsic safety details.

### 2.7.1 Programming and adjustment

The main counter programme menu is extended as shown in Fig 2.6 to accommodate the 4/20mA calibration functions.

The '4-20 OP' programme function allows the 4/20mA output current to correspond to any positive total or rate display. e.g. 4mA could represent 0 counts and 20mA 5000 counts.

**Note:** Negative display numbers can not be represented by the 4/20mA output.

To calibrate the 4/20mA output current, enter the programme mode by operating the *P* and *E* push-buttons simultaneously. Using the *Up* or *Down* push-button select the function '4-20 OP' and press *P* which will result in the BA368C displaying the first sub-menu function '4.000'. – See Fig 2.6. Using the *Up* or *Down* push-button select the '4-20 tYPE' function which enables the 4/20mA output to be controlled by the total or rate display. Press *P*, select the required source and then return to the sub-menu by pressing the *E* button.

The displayed values which correspond to 4mA and 20mA output may now be defined. Using the *Up* or *Down* push-button select the '4.000' prompt for the function which defines the display at which the output current will be 4.000mA. Press *P* to reveal the existing setting with the most significant digit flashing. The decimal point will be fixed in the position already defined for the display by the 'd.P' function. The value of the flashing digit may be changed by pressing the *Up* or *Down* buttons. When this digit is set as required, pressing *P* will transfer control to the next digit.

When the required display has been entered, press the *E* button to return to the '4.000' prompt.

To enter the display at which the output current will be 20.000mA, press the *Up* or *Down* button to select the '20.000' prompt followed by *P* to reveal the current setting, which may be changed in the same way as the 4mA setting. When adjusted as required, press *E* three times to return to the display mode via the '20.000' and '4-20 OP' prompts.

The 4/20mA output may be calibrated to increase or decrease as the display increases, and most instruments will produce a linear output between 3.5 and 22mA.

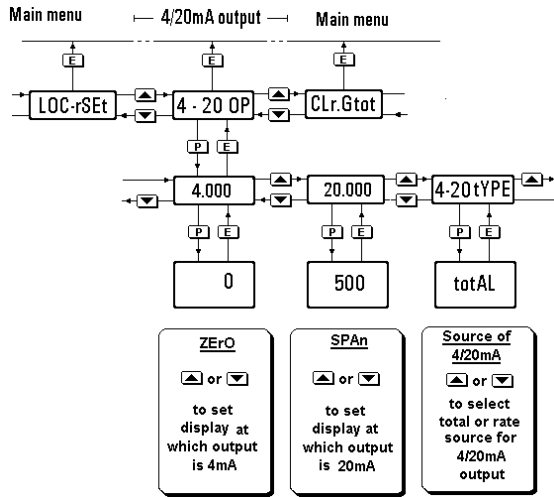

Fig 2.6 4/20mA output programme structure

**Note:** If the counter display calibration is changed by adjusting the scale factors, timebase or the position of the displayed decimal point, the 4/20mA output will automatically be set to give a constant 3.5mA output irrespective of the total or rate display. The 4/20mA output must therefore always be recalibrated following recalibration of the counter.

**2.8 OPTIONAL PULSE OUTPUT**

The BA368C can be supplied with an isolated retransmitted pulse output which may be used to operate remote instrumentation. The pulse output is only functional when the BA368C is programmed as a counter with an 'A : b' input count mode (Input A + Input B). See section 2.5.4

This output is a polarised current sink so current will only flow in one direction. Terminal P1 should be connected to the positive side of the supply.

$$\begin{aligned} R_{on} &= 60\Omega + 3V \\ R_{off} &= 1M \end{aligned}$$

See section 1.9.4.1 for details of intrinsic safety.

**2.8.1 Programming and adjustment**

The main counter programme menu is extended as shown in Fig 2.7 to accommodate the re-transmitted pulse output calibration functions.

How frequently a pulse is generated is defined by the 'diUide' function. When set to 1, an output pulse will be generated each time the least significant digit of the total display is incremented. This may be reduced in multiples of 10. e.g. if 'diUide' is set to 1,000 the least significant digit must be incremented 1,000 times before an output pulse is generated.

Output pulse width is determined by the 'durAtion' function which allows the width of the output pulse, and the minimum time between pulses, to be set between 2.5ms and 50ms.

The re-transmitted output pulse is not synchronous with the input pulse. If the two pulse output functions are set such that there is not enough time for the BA368C to output the required number of pulses in real time, they will be stored and output as quickly as possible.

If the instrument power supply fails or is disconnected, any untransmitted output pulses will be lost.

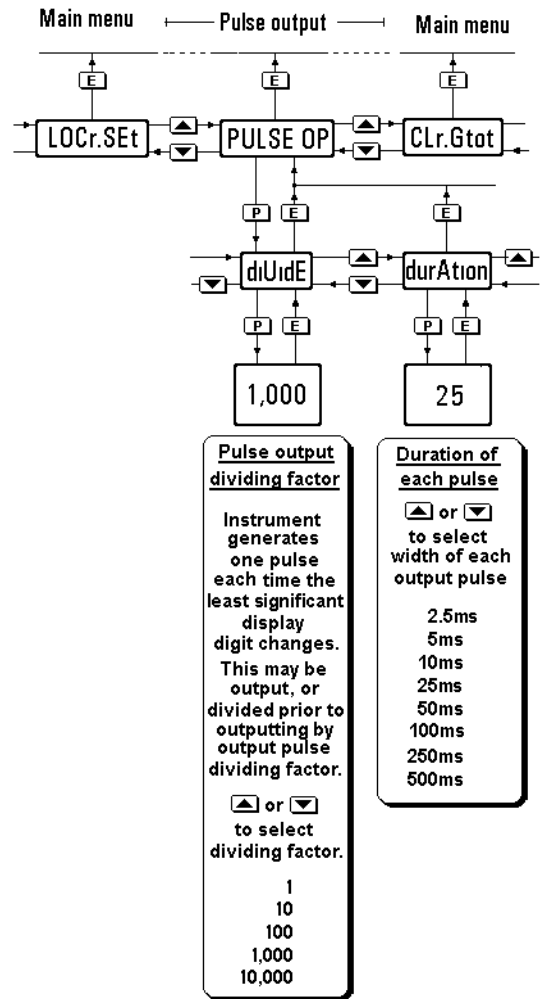

Fig 2.7 Pulse output menu

## 2.9 CALIBRATION EXAMPLE

A BA368C is required to display the position and speed, including direction, of a cable which is sensed by two proximity detectors mounted on a wheel with a circumference of 1m over which the cable runs. The sensors, which produce fifteen pulses per revolution, are positioned so their outputs are electrically 90° apart. The BA368C is required to display the position of the cable relative to a starting point in metres with a resolution of 0.1m, and to show speed of the cable in metres per second with a resolution of 1m. The total display (position) is to be resettable by an external contact, not from the BA368C front panel. To prevent tampering the instrument programme menu is to be protected by security code 1209

The BA368C may be calibrated on-site without disconnection from the power supply or from the two proximity detectors.

### Step 1 Enter the programming mode

Put the BA368C in the programming mode by simultaneously pressing *P* and *E*. Assuming a security code has not already been entered the instrument will respond by displaying 'Functlon' which is the first parameter in the main menu. See Fig 2.3

### Step 2 Select the instrument function

With 'Function' displayed, press *P* to reveal the existing instrument function. If this is not 'CountEr', select 'CountEr' using the *Up* or *Down* button. To prevent accidental changes the new setting will only be executed after the pass word 'SurE' has been entered.

Press *P* which will produce a display of 'Set nO' with the 'nO' flashing. Using the *uP* or *Down* button change 'nO' to 'YES' and press *P* again which will result in a display of '0000'. Using the *Up* or *Down* button to adjust each digit and the *P* push-button to transfer control to the next digit, enter the pass word SurE.

**Note:** S is entered as 5.

Finally, press *E* which will execute the function change and return the instrument to the 'Functlon' prompt in the main menu.

### Step 3 Select the type of inputs

Using the *Up* or *Down* button scroll through the main menu until 'InPut A'

is displayed; press *P* to reveal the existing setting. Using the *Up* or *Down* buttons select 'Pr.dEt', the input for a 2-wire proximity detector, and then return to the 'InPut' prompt in the main menu by pressing *E*.

Repeat for the second input 'InPut b'

### Step 4 Select input count mode

The two proximity detectors are positioned so their outputs are electrically 90° apart. From this information, in the quadrature input mode the BA368C can sense the direction of wheel rotation. Hence, the relative position of the cable can be displayed

Select 'Count' from the main menu and press *P*. Using the *Up* or *Down* button select 'A rEL b' the quadrature function and press *E* to return to the 'Count' prompt in the main menu.

### Step 5 Counting edge

The proximity detector current rises when it detects a marker on the wheel. The BA368C is therefore required to count when the proximity detector current changes from low to high i.e. a rising edge.

Select 'Cnt EdGE' from the main menu and press *P* to show the existing setting. Using the *Up* or *Down* button select "EdGE 2" followed by *E* to enter the selection and return to the main menu.

### Step 6 Activate lower rate display

A rate display is required so the lower display must be activated.

Select 'dISPLAY.2' from the main menu and press *P* to show the existing setting. Using the *Up* or *Down* button select 'On' followed by *E* to enter the selection and return to the main menu.

### Step 7 Position of decimal point

In this example the BA368C is required to display total (position) with a resolution of one decimal place and rate (speed) with no decimal point.

Select 'd.P.' from the main menu and press *P*. The display will be activated

with one digit plus the following decimal the *Up* or *Down* button until the second least significant digit and following decimal point are flashing. Press

Transfer control to lower rate display by operating the *P* button. Press the *Up* or *Down* button until the right hand digit is flashing which will result in no decimal point being displayed.

Finally press *E* to return to the 'd.P'. prompt in the main menu.

### Step 8 Enter the total scale factor

In this example the proximity detectors produce fifteen pulses per one metre movement of the cable. The position display is required in metres so the total (position) scale factor 'SCALE-t' should be set to 15.0 (may be entered at 15)

Select 'SCALE-t' from the main menu and press *P* which will show the current figure with one digit flashing. To position the decimal point, operate the *P* push-button to move the flashing digit to the second least significant digit. Pressing the *Up* and *Down* buttons simultaneously will then fix the decimal point in front of the least significant digit.

Using the *Up* and *Down* buttons to adjust each digit in turn and the *P* button to transfer control between digits, enter 15.0 (may be entered as 15). Finally return to the 'SCALE-t' prompt in the main menu by pressing *E*.

### Step 9 Enter the rate scale factor

In this example the proximity detectors produce fifteen pulses per one metre movement of the cable. The rate display is required in metres per second so the rate (speed) scale factor SCALE-r should be set to 15.0 (may be entered as 15)

Select 'SCALE-r' from the main menu and press *P* which will show the current figure with one digit flashing. To position the decimal point, operate the *P* push-button to move the flashing digit to the second least significant digit. Pressing the *Up* and *Down* buttons

simultaneously will then fix the decimal point in front of the least significant digit.

Using the *Up* and *Down* buttons to adjust each digit in turn and the *P* button to transfer control between digits, enter 15.0 (may be entered as 15). Finally return to the 'SCALE-r' prompt in the main menu by pressing *E*.

### Step 10 Set the display timebase

Select 't-bASE' from the main menu and press *P* to show the current setting. In this example the rate display (speed) is required in metres per second. Using the *Up* or *Down* button scroll through the three options and select 'tb-1'. Return to the 't-bASE' prompt in the main menu by pressing *E*.

### Step 11 Adjust the rate display filter

The rate display filter parameters should be adjusted experimentally after installation to provide a stable rate display with an acceptable step response.

During commissioning it is recommended that initially the second digit of the rate parameters is set to 0 (step response off) and the first digit (amount of filtering) is adjusted to provide acceptable rate display stability. The second digit should then be increased until acceptable rate display stability is once again achieved.

To adjust the filter parameters select 'FILtEr' from the main menu and press *P* to reveal the current setting. The first digit will be flashing and may be adjusted using the *Up* or *Down* button. The *P* button will transfer control to the second digit. When both are set as required, return to the 'FILtEr' prompt in the main menu by pressing *E*.

**Note:** While adjusting the filter, the rate is shown on the lower display so that stability can be assessed.



**Step 12 Direction of count**

In this application the direction of count will determine whether a cable movement is shown as a positive or negative position and rate. If input A occurs before input B, a positive display will result when the BA368C is programmed to count up.

Select 'uP' or 'dn' from the main menu and press *P* to show the existing setting. Using the *Up* or *Down* button select 'uP' followed by *E* to enter the selection and return to the main menu.

**Step 13 Reset value**

When the remote reset switch is operated the total display (position) is required to be set to zero.

Select 'rSEt UAL' from the main menu and press *P* which will show the current figure with one digit flashing. Using the *Up* and *Down* buttons to adjust each digit in turn and the *P* button to transfer control between digits, enter 0000000.0. Finally return to the 'rSEt UAL' prompt in the main menu by pressing *E*.

**Step 14 Turn local reset off**

In this example the operator must not be able to zero the total (position) display from the instrument front panel. The local reset function should therefore be turned off.

Select 'LOC-rSEt' from the main menu and press *P* which will reveal if it is turned 'On' or 'OFF'. Using the *Up* or *Down* button toggle the display to 'OFF' and press *E* to return to the 'LOC-rSEt' prompt.

**Step 15 Define the security code**

Defining a security code prevents unauthorised access to the programme functions. Select 'COdE' from the main menu and press *P* which will reveal the existing security code. Using the *Up* and *Down* buttons enter the new code 1209 digit by digit. The *P* button will transfer control between digits. When the new code has been entered, press *E* to return to the main programme menu.

**Step 16 Return to the display mode**

Following completion of programming and calibration, return the BA368C to the display mode by pressing *E*. All the programming functions will now be stored in permanent memory and will be protected from accidental or unauthorised adjustment by the security code.

## 2.10 MAINTENANCE

### 2.10.1 Fault finding during commissioning

If a BA368C counter fails to function during commissioning the following procedure should be followed:

Symptom	Cause	Check:
No display	Incorrect wiring Note: Terminals 2, 4, 6 & 8 are interconnected within the BA368C	That there is between 10 and 28V on terminals 1 & 2 with terminal 1 positive.
Total display not counting	Incorrect programming or input wiring	That instrument has been programmed for the transducer(s) in use, and that they are connected to the correct terminal with correct polarity.  Total scale factor
No rate display	Lower display 'DISPLAY.2' not switched on.	Programming see 2.5.7  Rate scale factor
Rate display always zero	Reset terminals connected together	Wiring & reset switch.
Colon appears between digits in display	Display has overranged	Calibration and if necessary reduce number of digits displayed.
Unable to enter programme mode	Incorrect security code	That correct security code is being used, or fit security link in override position. See Fig 1.4
Rate and total displays are not direction sensitive.	Incorrect input count mode or transducer	Input count mode and operation of transducer.  Presence of pulse signal at both inputs.
4/20mA output is constant 3.5mA	Counter parameters have been changed	Programming of 4/20mA output see 2.7.1
Re-transmitted pulse output not working	Incorrect programming	Counter is programmed for A + b input see 2.5.4

### 2.10.2 Fault finding after commissioning

#### ENSURE PLANT SAFETY BEFORE STARTING MAINTENANCE

**Live maintenance is permitted on intrinsically safe equipment installed in a hazardous area, but only certified test equipment should be used unless a gas clearance certificate is available.**

If a BA368C counter fails after it has been functioning correctly, the following table may help to identify the cause of the failure.

Symptom	Cause	Check:
No display	No power supply.	That there is between 10 and 28V on terminals 1 & 2.
Rate display always zero	Transducer or associated wiring has been damaged.	Presence of pulse signal at input terminals .
Total display not functioning	Remote reset contact closed	That remote reset contact is not closed or associated wiring damaged.
Colon appears between digits in display	Display has overranged	Calibration and if necessary reduce number of digits displayed.
Rate and total displays are not direction sensitive.	Damage to transducer or input wiring.	Presence of pulse signal at input terminals.

If this procedure does not reveal the cause of the fault, it is recommended that the instrument is returned to BEKA associates or to our agent in your area for repair.

## 2.11 INDEX FOR COUNTER SECTION

Subject	Section	Subject	Section
ATEX intrinsic safety certification	1.4; 2.2	Rate	
Alarms optional	2.6	Display filter	2.5.10
Access setpoint	2.6.10	Scale factor	2.5.9
Delay	2.6.8	Reset	
Enable	2.6.2	Grand total	2.5.15
Function	2.6.5	Total display	2.3.3; 2.4.3;
Hysteresis	2.6.7		2.5.14
Intrinsic safety	1.9.3.2	Value	2.5.13
Normally open or closed	2.6.6	Security	
Setpoint	2.6.4	Code	2.5.16
Silence time	2.6.9	Override link	1.6.1
Solid state outputs	1.9.3.1	Servicing	1.7
Type	2.6.3	Timebase	2.5.11
Backlight optional	1.9.6	Total	
Calibration	2.5; Fig 2.3	Scale factor	2.5.8
Controls	2.1.2	Zener barriers use with	2.3
Counting		4/20mA output optional	2,7
Direction	2.5.12	Intrinsic safety	1.9.5.1
Edge	2.5.5	Programming & adjustment	2.7.1; Fig 2.6
Mode	2.5.4		
Decimal points	2.5.6		
Display	2.1.3		
Filter (rate)	2.5.10		
Lower	2.5.7		
Rate	2.5.7		
Resetting total	2.3.3; 2.4.3		
	2.5.14		
Function of instrument	2.5.2		
Grand total	2.1; 2.1.3		
Resetting	2.5.15		
Guarantee	1.7.2		
Galvanic isolator use with	2.4		
Input	2.3.2; 2.4.2;		
	2.5.3		
Installation	1.5		
Location	1.5.1		
Maintenance	2.10		
Routine	1.7.1		
Power supply	2.3.1; 2.4.1		
Pulse output optional	2.8		
Intrinsic safety	1.9.4.1		
Programming & adjustment	2.8.1; Fig 2.7		



## Section 3 Use as a Timer

- 3.1 Description**
  - 3.1.1 Initialisation & loss of power
  - 3.1.2 Controls
  - 3.1.3 Displays
- 3.2 System certificates**
- 3.3 Use with Zener barriers**
  - 3.3.1 Power supply
  - 3.3.2 Inputs
  - 3.3.3 Resetting the timer
  - 3.3.4 Options
- 3.4 Use with galvanic isolators**
  - 3.4.1 Power supply
  - 3.4.2 Inputs
  - 3.4.3 Resetting the timer
  - 3.4.4 Options
- 3.5 Programming**
  - 3.5.1 Accessing programme functions
  - 3.5.2 Function of instrument
  - 3.5.3 Type of input
  - 3.5.4 Start and stop
  - 3.5.5 Units of display
  - 3.5.6 Set time
  - 3.5.7 Access set time setpoint
  - 3.5.8 Direction of count
  - 3.5.9 Lower display (set time)
  - 3.5.10 Continue cycle
  - 3.5.11 Local reset of timer
  - 3.5.12 Resetting elapsed time grand total.
  - 3.5.13 Security code
- 3.6 Optional Control Outputs**
  - 3.6.1 Programming and adjustment
  - 3.6.2 Control output enable
  - 3.6.3 Control output on at:
  - 3.6.4 Control output off at:
  - 3.6.5 Output on delay time
- 3.7 Applications**
- 3.8 Maintenance**
  - 3.8.1 Fault finding during commissioning.
  - 3.8.2 Fault finding after commissioning.
- 3.9 Index for Timer section**

### 3.1 DESCRIPTION

When programmed as a timer the BA368C may be used to measure and display the elapsed time between external events, or to control external events via the two optional control outputs. The maximum timer duration is 99 hours, 59 minutes and 59 seconds.

The BA368C may be programmed to time up from zero to a setpoint, or to time down from a setpoint. Times are entered in hours, minutes and seconds, but may be displayed in hours, minutes and seconds or in just hours and minutes. Elapsed or remaining time is continuously displayed and a separate display may be activated to show the timer setpoint 'SEt t'. The timer can be started and stopped from the front panel push-buttons, or by remote switches or sensors. Similarly, the instrument may be reset from the front panel, or by closure of a remote contact.

A grand total time is maintained which can viewed by operating the front panel push-buttons, but can only be reset from within the programme menu.

#### 3.1.1 Initialisation and loss of power

The BA368C timer can be programmed to auto-reset after initialisation, or to continue timing from the point at which power was disconnected. When programmed to continue timing, the two optional control outputs, if fitted, will be restored to their state when power was lost.

However programmed, when the power supply is interrupted all programme parameters, the displayed elapsed time and the grand total time will be automatically stored in permanent memory.

#### 3.1.2 Controls

The BA368C timer is controlled and calibrated via four front panel push-button switches. In the display mode i.e. when the instrument is displaying time the switch functions are:

#### Description of Switch Functions

<b>Down</b>	When enabled, starts the timer. See section 3.5.4
<b>Up</b>	When enabled, stops the timer. See section 3.5.4

#### Description of Switch Functions

<b>E+Down</b>	While these buttons are pushed, the display will show the grand total time in hours and tenths of an hour and the grand total annunciator will be activated. See section 3.5.12
<b>Down+Up</b>	Resets the timer to zero or to the set time setpoint ('SEt t') when these two push-buttons are operated simultaneously for more than two seconds. Selectable function from programme menu. See section 3.5.11
<b>P+Down</b>	While these buttons are pushed the instrument will display the firmware and version numbers plus the programmed function.
<b>P+Up</b>	When enabled, operating these buttons simultaneously gives direct access to the set time setpoint ('SEt t') from the display mode. See section 3.5.7

#### 3.1.3 Displays

The BA368C timer has two digital displays and associated annunciators.

<b>Elapsed time display</b>	When counting up, total time since timer was started; when counting down, the remaining time until SEt t has elapsed. Display may be formatted as hh:mm or hh:mm:ss
<b>Set time display</b>	Shows set time setpoint ('SEt t') on lower display. May be turned off. See 3.5.9
<b>Reset Annunciator</b>	Activated while timer is being reset.
<b>Grand total Annunciator</b>	Activated while E + Down push-buttons are operated. Grand total time shown on lower display.
<b>Control Output Annunciators</b>	Activated when optional control output is activated.

**3.2 SYSTEM CERTIFICATES**

In addition to the ATEX EC-Type Examination Certificate, ITS have issued two system certificates. One defines how the BA368C may be used with Zener barriers and the other with galvanic isolators.

Interface	Certificate No
Zener barriers	Ex01E2007
Galvanic isolators	Ex01E2008

This section interprets these system certificates and illustrates how to design timer systems with Zener barriers and galvanic isolators.

System certificates are Certificates of Conformity which are primarily issued for guidance in the UK. They do not form part of certification to the European ATEX Directive.

**3.3 USE WITH ZENER BARRIERS**

Zener barriers are the least expensive intrinsically safe interface between a safe and hazardous area. However, they do not provide isolation and require a high integrity earth connection that may be expensive to install. For a single BA368C timer it may be less expensive and complicated to use galvanic isolators when a high integrity earth connection is not already available.

Any certified Zener barrier may be used with the BA368C providing its output parameters do not exceed the input parameters of the terminals to which they are connected. Only one polarity of Zener barrier i.e. positive or negative, may be used with each instrument.

To assist with system design, the Zener barrier system certificate specifies the maximum output parameters of the Zener barriers that may be connected to the BA368C and defines the maximum cable parameters. Diode return barriers are identified by manufacturers type number, although alternatives may be used.

The basic system used for all BA368C hazardous area timer installations is shown in Fig 3.1 Intrinsic safety requirements are explained in section one of this manual which should be read before the system is designed.

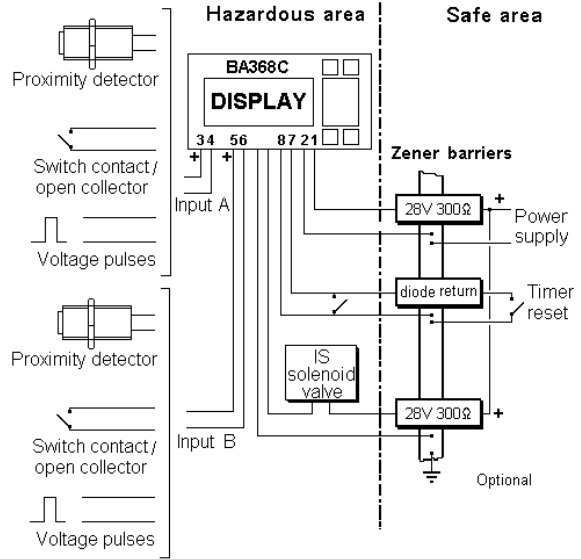

Fig 3.1 Timer installation using barriers

If the timer is reset from the instrument front panel, or from an external switch in the hazardous area, a reset Zener barrier is not required.

In Fig 3.1 the timer has one optional output switching an intrinsically safe solenoid valve. Inputs A and B are in the hazardous area but each may be transferred from the safe area via a Zener barrier.

**3.3.1 Power supply**

A BA368C is powered from the safe area via a positive polarity 28V 300Ω Zener barrier which will have an end-to-end resistance of about 340Ω. When operating as a timer with two proximity detector inputs, the BA368C consumes approximately 20mA and requires a minimum voltage of 10V between terminals 1 and 2. The supply voltage in the safe area must therefore be between 16.8V and the maximum working voltage of the Zener barrier – usually about 26V.

### 3.3.2 Inputs

When the BA368C is programmed as a timer both input A and input B are operational and may be independently programmed to operate with almost any pulse output transducer.

The following table shows the switching thresholds for the various transducers. For reliable operation the input signal must fall below the lower threshold and rise above the upper threshold.

Input	Switching thresholds	
	Switch	100Ω
Proximity detector	1.2mA	2.1mA
Open collector	2kΩ	10kΩ
Magnetic pick-off	0mV	20mV peak
Voltage pulse	1.0V	3.0V

The intrinsic safety requirements are explained in section 1.4.3. Almost any mechanically or magnetically activated switch, intrinsically safe NAMUR 2-wire proximity detector or intrinsically safe voltage may be directly connected to these two inputs.

If the BA368C is located in a hazardous area but the transducer(s) is in a safe area, a Zener barrier is required to transfer the transducer output to the instrument. The system certificate defines barriers which may be used.

### 3.3.3 Resetting the timer

When terminals 7 & 8 are connected together the timer will be reset to zero if counting up and to the set time ('SEt t') if counting down. To achieve reliable resetting the contacts must close for at least one second.

Resetting may be accomplished by any mechanically operated switch located in the hazardous area providing it can withstand a 500V rms insulation test to earth for one minute. No Zener barrier is required.

The BA368C timer may also be reset from within the safe area. Any switch may be used but a Zener barrier is required to transfer the contact closure into the hazardous area. A diode return barrier may be combined with the supply barrier so that only one dual channel device is required. The system certificate lists some of devices that may be used.

Fig 3.1 illustrates how the timer may be reset from both the safe and the hazardous areas.

### 3.3.4 Options

When the BA368C is calibrated as a timer, optional control outputs may be used. The intrinsic safety features of these are described in section 1.9.3.2 of this manual.

## 3.4 USE WITH GALVANIC ISOLATORS

Galvanic isolators are probably the easiest intrinsically safe interface to use as they provide isolation and do not require a high integrity earth connection.

Any EEx ia IIC certified intrinsically safe galvanic isolators may be used with the BA368C providing the output parameters do not exceed the input parameters of the terminals to which they are connected.

To assist with system design, the galvanic isolator system certificate lists some of the isolators that may be used and defines the maximum permitted cable parameters.

Fig 3.2 illustrates the basic circuit that is used for all BA368C timer installations protected by galvanic isolators. Intrinsic safety requirements are explained in section one of this manual which should be read before the system is designed.

If the timer is reset from the instrument front panel, or from an external switch in the hazardous area, the reset galvanic isolator is not required.

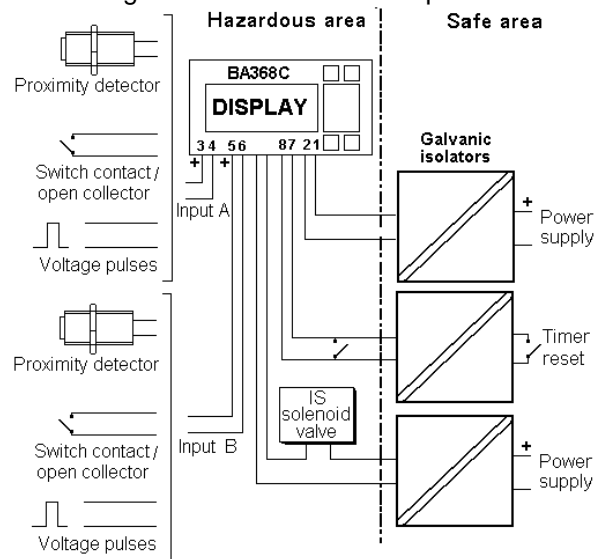

Fig 3.2 Basic timer circuit using isolators

In Fig 3.2 the timer has one optional control output switching an intrinsically safe solenoid valve. The inputs are shown in the hazardous area, but each may be transferred from the safe area via a galvanic isolator or intrinsically safe relay.



### 3.4.1 Power supply

The BA368C galvanic isolator system certificate lists a wide range of certified galvanic isolators that may be used to power the instrument. If using the entity concept to select an isolator, in addition to matching the safety parameters, the isolator must be capable of supplying 10V dc minimum at 20mA to the BA368C.

### 3.4.2 Inputs

When the BA368C is programmed as a timer both input A and input B are operational and may be independently programmed to operate with almost any pulse output transducer.

The following table shows the switching thresholds for the various transducers. For reliable operation the input signal must fall below the lower threshold and rise above the upper threshold.

Input	Switching thresholds	
	Switch	100Ω
Proximity detector	1.2mA	2.1mA
Open collector	2kΩ	10kΩ
Magnetic pick-off	0mV	20mV peak
Voltage pulse	1.0V	3.0V

The intrinsic safety requirements are explained in section 1.4.3. Almost any mechanically or magnetically activated switch, intrinsically safe NAMUR 2-wire proximity detector or intrinsically safe voltage may be directly connected to these two inputs.

If the BA368C is located in a hazardous area but the transducer(s) is in a safe area, a galvanic isolator is required to transfer the transducer output to the instrument. The system certificate defines some galvanic isolators which may be used.

### 3.4.3 Resetting the timer

When terminals 7 & 8 are connected together the timer will be reset to zero if counting up, and to the set time ('SEt t') if counting down. To achieve reliable resetting the contacts must close for at least one second.

Resetting may be accomplished by any mechanically operated switch located in the hazardous area providing it can withstand a 500V rms insulation test to earth for one minute. No galvanic isolator is required.

The BA368C timer may also be reset from within the safe area. Any switch may be used but a galvanic isolator is required to transfer the contact closure into the hazardous area. The system certificate lists some of devices that may be used.

Fig 3.2 illustrates how the timer may be reset from both the safe and the hazardous areas.

### 3.4.4 Options

When the BA368C is calibrated as a timer, optional control outputs may be used. The intrinsic safety features of these are described in section 1.9.3.2 of this manual.

### 3.5 PROGRAMMING

Throughout this manual push-buttons are shown in italics e.g. *P* or *Up* push-button, and legends displayed by the instrument are shown within inverted commas e.g. 'InPut A' and 'COdE'.

#### 3.5.1 Accessing programme functions

Access to the programme menu is obtained by operating the *P* and *E* push-buttons simultaneously. If the BA368C is not protected by a security code the first parameter 'Function' will be displayed. If a security code other than the default code 0000 has already been entered, the instrument will display 'COdE'. Press *P* to clear this prompt and enter the security code for the instrument using the *Up* or *Down* push-button to adjust each digit, and the *P* push-button to move control to the next digit. If the correct code has been entered pressing *E* will cause the first parameter 'Function' to be displayed. If an incorrect code is entered, or a push-button is not operated within ten seconds, the instrument will automatically return to the display mode.

Once within the main programme menu the required parameter can be reached by scrolling through the menu using the *Up* and *Down* push-buttons as shown by the counter programme structure in Fig 3.3.

This section summarises all the timer programmable parameters excluding the optional control outputs. When read in conjunction with Fig 3.3 it provides a quick aid for programming the instrument. If more detail is required, each section contains a reference to a full description of the function.

Programming details for the optional control outputs are contained in section 3.6.

### SUMMARY

<u>Display</u>	<u>Description of function</u>																		
'Function'	<p><b>Function of instrument</b> Enables the BA368C to be conditioned as a counter, timer, tachometer or clock. After making the selection 'SurE' has to be entered to confirm the instruction Select 'ELAPSE' to enable the timer functions. See section 3.5.2</p>																		
'InPut A'	<p><b>Type of input</b> Conditions input A to work with one of five types of transducer: 'UOLtS' Voltage pulse 'COIL' Magnetic pick-off 'Pr.dEt' NAMUR proximity detector. 'COntACT' Switch contact 'OP.COL' Open collector See section 3.5.3</p>																		
'InPut b'	<p><b>Type of input</b> As above but for input B See section 3.5.3</p>																		
'StArStOP'	<p><b>Start and stop timer</b> Defines how the timer is started and stopped:</p> <table border="1"> <thead> <tr> <th></th> <th>Start*</th> <th>Stop*</th> </tr> </thead> <tbody> <tr> <td>'Control1'</td> <td>A high</td> <td>B high</td> </tr> <tr> <td>'Control2'</td> <td>A low</td> <td>B low</td> </tr> <tr> <td>'Control3'</td> <td>A high</td> <td>A low</td> </tr> <tr> <td>'Control4'</td> <td>A low</td> <td>A high</td> </tr> <tr> <td>'LOCAL'</td> <td><i>Down</i></td> <td><i>Up</i></td> </tr> </tbody> </table> <p>*See section 3.5.4 (voltage input)</p>		Start*	Stop*	'Control1'	A high	B high	'Control2'	A low	B low	'Control3'	A high	A low	'Control4'	A low	A high	'LOCAL'	<i>Down</i>	<i>Up</i>
	Start*	Stop*																	
'Control1'	A high	B high																	
'Control2'	A low	B low																	
'Control3'	A high	A low																	
'Control4'	A low	A high																	
'LOCAL'	<i>Down</i>	<i>Up</i>																	
'UnitS'	<p><b>Units of display</b> Defines the units of the timer display. Two alternative formats are available, hours and minutes 00:00 or hours, minutes and seconds 00:00:00. See section 3.5.5</p>																		
'SEt t'	<p><b>Set time</b> Set time is the timer setpoint which may be entered in the programme or display modes. The timer may be programmed to count up to, or down from the Set Time. See section 3.5.6</p>																		

<u>Display</u>	<u>Description of function</u>
'AcSEt t'	<p><b>Access Set Time</b> Sub-menu that enables the timer setpoint 'Set t' to be adjusted from the display mode. A separate security code prevents unauthorised access. See section 3.5.7</p>
'uP or dn'	<p><b>Direction of count</b> Determines whether the timer counts from zero upwards, or from the set time setpoint Set t downwards. See section 3.5.8</p>
'DISPLAY.2'	<p><b>Lower display (Set t)</b> Turns the lower display, which shows the timer setpoint 'SEt t', on or off. See section 3.5.9</p>
'ContinuE'	<p><b>Continue cycle</b> Determines how the timer powers-up after a power supply interruption. When 'OP.OFF' is selected, both optional control outputs will be open. When 'OP.rEStOr' is selected, both control outputs will be returned to their status when power was removed. After power restoration the timer will always return in the stopped condition. See section 3.5.10</p>
'LOC-rSEt'	<p><b>Local reset</b> When turned 'On' the timer may be reset from the display mode by simultaneously operating the <i>Up</i> and <i>Down</i> push-buttons for at least two seconds. See section 3.5.11</p>
'CLr.Gtot'	<p><b>Resetting grand total time</b> This function resets the grand total time to zero when 'CLr YES' is selected, and 'SurE' is entered to confirm the instruction. <b>Note:</b> Once cleared, a grand total time can not be recovered. See section 3.5.12</p>

<u>Display</u>	<u>Description of function</u>
'COdE'	<p><b>Security code</b> Defines a four digit numeric code which must be entered to gain access to the programmable functions. Default code 0000 disables the security function and allows unrestricted access to all programmable functions. See section 3.5.13</p>

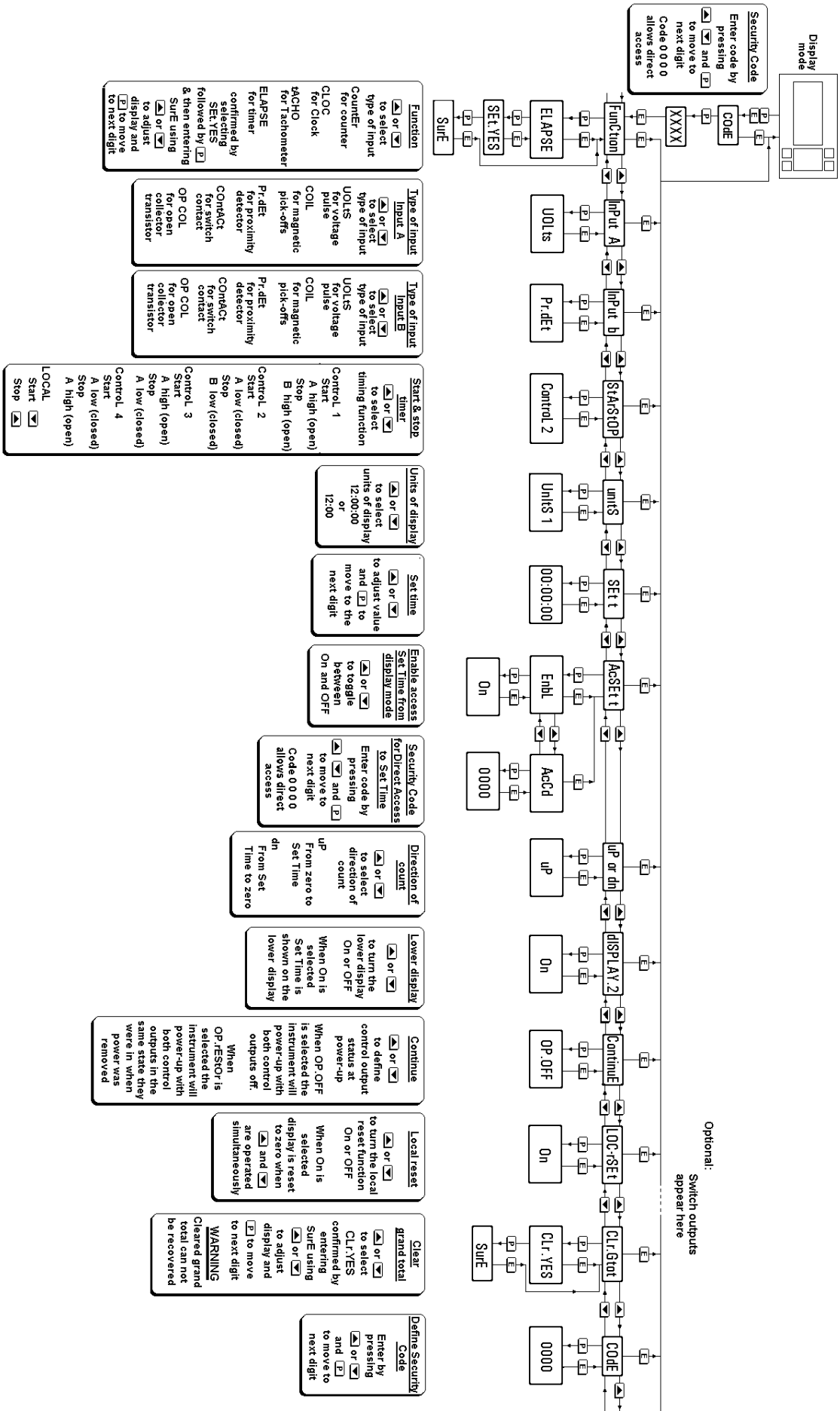

Fig 3.3 Timer programme structure

### 3.5.2 Function of instrument: 'Function'

This is the first parameter in the programme menu which conditions the instrument as a counter, timer, tachometer or as a clock.

#### CAUTION

**Function must be defined before any of the other parameters are programmed. It is protected by a password to prevent accidental changes.**

To define the function of the instrument select 'Function' from the main menu and press *P* which will reveal the existing setting. Pressing the *Up* or *Down* button will scroll through the four options:

Display	Instrument function
'CountEr'	Counter
'CLOC'	Clock
'tACHO'	Tachometer
'ELAPSE'	Timer

When 'ELAPSE' is displayed, press *P* which will result in 'SEt.nO' being displayed. To proceed press *Up* or *Down* which will change this to 'SEt.YES'. To confirm the function change, press *P* which will result in prompt 'SEt 0000' with one digit flashing. Using the *Up*, and *Down* buttons and the *P* button to move to the next digit, enter the password 'SurE'. Note 'S' is entered as '5'. Finally, pressing *E* will execute the change to a timer and return the display to the 'Function' prompt in the main menu.

### 3.5.3 Type of input: 'InPut A' and 'InPut b'

To define an input type select 'InPut A' or 'InPut b' from the menu and press *P*, which will reveal the current input type. Pressing the *Up* or *Down* button will scroll through the five options:

'UOLtS'	Voltage input Threshold 1V and 3V
'COIL'	Low voltage Threshold 20mV peak
'Pr.dEt'	NAMUR proximity detector Threshold 1.2 and 2.1mA
'COntACT'	Switch contact Threshold 100 and 1000Ω
'OP.COL'	Open collector Threshold 2kΩ and 10kΩ

When the required type of input has been selected press *E* to enter the selection and return to the 'InPut A' or 'InPut b' prompt in the main menu.

**Note:** To operate reliably, the input signal must fall below the lower switching threshold and rise above the upper switching threshold.

### 3.5.4 Start and stop: 'StArStOP'

This function defines how the timer is started and stopped. Five options are selectable, allowing the timer to be controlled by inputs A and B or from the front panel push buttons.

To check or change how the timer is controlled, select 'StArStOP' from the main menu and press *P* which will reveal the current setting. The options are shown in the following tables.

#### Voltage inputs and control from front panel

Display	Start	Stop
'Control1'	A high	B high
'Control2'	A low	B low
'Control3'	A high	A low
'Control4'	A low	A high
'LOCAL'	<i>Down</i> button	<i>Up</i> button

#### Contact and open collector inputs

Display	Start	Stop
'Control1'	A open	B open
'Control2'	A closed	B closed
'Control3'	A open	A closed
'Control4'	A closed	A open

#### Proximity detector inputs

Display	Start	Stop
'Control1'	A low	B low
'Control2'	A high	B high
'Control3'	A low	A high
'Control4'	A high	A low

When the required option has been selected press *E* to return the instrument to the main menu.

**Notes:** The timer controls have been allocated the following relative priorities:

#### Reset, Set time, Stop, Start

Stop therefore always overrides start.

When the timer elapsed time equals the set time SEt t, an internal stop signal is generated which automatically stops the timer.

### 3.5.5 Units of display: 'UnitS'

This function defines whether the timer displays seconds.

To check or change the units select 'UnitS' from the main menu and press *P* which will reveal the current setting. Pressing the *Up* or *Down* button will toggle between the two display options:

Display	Units
'12 : 00'	HH : MM
'12 : 00 : 00'	HH : MM : SS

When the required display has been selected press *E* to enter the option and return the instrument to the main menu.

**Note:** In the HH:MM mode, the displayed colon flashes when the timer is running.

### 3.5.6 Set Time: 'SEt t'

Set time is the setpoint which the timer counts to or from, depending upon whether it has been programmed as an up or down timer.

To enter a set time select 'SEt t' from the main menu and press *P* which will reveal the existing value with one digit flashing. The value of the flashing digit can be changed by pressing the *Up* or *Down* buttons. When this digit is correct pressing *P* will transfer control to the next digit.

When entering set time, seconds are always displayed. Even if the timer has been programmed to display just hours and minutes, (see 3.5.5) the instrument continues to operate with a resolution of one second.

When the required set time has been entered, press *E* to store the setpoint and return to the main menu.

**Note:** Set time can also be entered directly from the display mode. – see 3.5.7

### 3.5.7 Access set time setpoint: 'AcSEt t'

This function activates a separate menu that provides direct access to the timer setpoint ('SEt-t') when the instrument is in the display mode i.e. when displaying elapsed time. An operator may therefore adjust the timer setpoint without having access to the programme menus. An optional security code may be used to prevent accidental adjustment.

This direct access menu is enabled and the separate security code defined from the 'AcSEt t' function in the main programme menu as shown in Fig 3.3

To activate this sub-menu select 'AcSEt t' from the programme menu and press *P*. This will display the enable prompt 'EnbL'. Pressing *P* again will

reveal if the direct access menu is 'On' or 'OFF'. The *Up* or *Down* buttons will toggle the display between the two conditions.

If 'OFF' is selected, the operator will not have access to the setpoint from the display mode. Return to the 'AcSEt t' prompt in the main menu by pressing *E* twice.

If 'On' is selected, the operator will have direct access to the set time setpoint from the display mode via a separate optional security code. To define this four digit numeric code press *E* to return to the 'EnbL' prompt followed by the *Up* or *Down* button to select the access code prompt 'AcCd'. Pressing *P* will then reveal the current security code with one digit flashing. The code may be changed by operating the *Up* or *Down* push-buttons and pressing the *P* button to transfer control to the next digit. Finally press *E* twice to enter the new security code and return to the 'AcSEt t' prompt in the programme menu.

Entering code 0000 will disable the security code allowing direct access to the setpoint from the display mode by pressing the *P* and *Up* buttons simultaneously.

New instruments are supplied with this security code set to 0000.

### 3.5.8 Direction of count: 'uP or dn'

The BA368C timer will time up from zero to the set time setpoint ('SEt t'), or down from the set time setpoint to zero.

To check or change the timing direction select 'uP or dn' from the menu and press *P* which will reveal the present setting. 'uP' indicates that the instrument is an up-timer and 'dn' that it is a down-timer. Pressing the *Up* or *Down* buttons will toggle the display between the two setting. When set as required, press the *E* button to enter the setting and return to the main menu.

### 3.5.9 Lower display: 'dISPLAY.2'

This function turns the lower display which shows the set time on or off. When turned off, the BA368C will display just the elapsed time when counting up, or the remaining time when counting down. When the lower display is turned on, the instrument will show elapsed or remaining time and the set time SEt t simultaneously.

To check the status of the lower display select 'dISPLAY.2' from the menu and press *P* which will reveal if the function is 'On' or 'OFF'. The setting can be changed by pressing the *Up* or *Down* button followed by the *E* button to return to the main menu.

### 3.5.10 Continue cycle: 'ContinuE'

This function determines how the timer operates when power is restored after an interruption. Two options are available.

#### 'OP.OFF'

When power is restored, after initialisation, the instrument will show the display(s) present when power was removed. The timer will then wait for a starting instruction. Both optional control outputs will be open.

#### 'OP.rESTOr'

When power is restored, after initialisation, the instrument will show the display(s) present when power was removed. The timer will then wait for a starting instruction. Both optional control outputs will be restored to their condition when power was removed.

To check or change the status of this function select 'ContinuE' from the main menu and press *P* which will reveal the current setting. Pressing the *Up* or *Down* buttons will toggle the display between 'On' and 'OFF'. When set as required, press the *E* button to enter the setting and return to the main menu.

### 3.5.11 Local reset of timer: 'LOC- rSET'

When local reset is turned on, operating the *Up* and *Down* push-buttons simultaneously for more than two seconds in the display mode will reset the timer.

To check the status of the local reset function select 'LOC-rSET' from the menu and press *P* which will reveal if the function is 'On' or 'OFF'. If required press the *Up* or *Down* button to change the setting, followed by the *E* button to return to the main menu.

The timer may also be reset remotely by connecting terminals 7 and 8 together.

### 3.5.12 Resetting elapsed time grand total: 'CLr. Gtot'

The grand total is a separate eight digit counter which totalises elapsed time in hours and tenths of an hour, but is not cleared when the timer is reset.

The grand total time may be viewed when the instrument is in the display mode by operating the *E* and *Down* push-buttons simultaneously.

The grand total time can only be reset to zero from the 'CLr. Gtot' function in the main programme menu. To zero the grand total select 'CLr. Gtot' and press *P* which will cause the instrument to display 'CLr. no' with 'no' flashing. Continuously press the *Up* or *Down* push-buttons until 'CLr. YES' is displayed and then press *P* which will result in a 'CLr. 0000' prompt with one digit flashing. Using the *Up*, and *Down* buttons and the *P* button to move to the next digit, confirm the request by entering the password 'SurE'. Note 'S' is entered as '5'. Pressing *E* will then reset the grand total counter to zero and return the instrument to the 'CLr. Gtot' prompt in the main menu.

#### WARNING

**After resetting the grand total to zero the old grand total can not be recovered.**

### 3.5.13 Security code: 'COdE'

The calibration and conditioning of the BA368C may be protected by a four digit security code which must be entered before access to the programme menu is allowed. New instruments are programmed with the default security code 0000 that allows unrestricted access to all programming functions without entering a security code.

To enter a new security code select 'COdE' from the menu and press *P* which will cause the instrument to display the current security code. Each digit of the code can be changed using the *Up* and *Down* push-buttons, and the *P* button to move to the next digit. When the required code has been entered press *E* to return to the main menu. The revised security code will be activated when the instrument is returned to the display mode.

If the security code is lost, access to the programmable functions can be obtained by moving the internal security link to the override position as shown in section 1.6.1. The original security code can then be viewed by selecting 'COdE' from the main menu and pressing *P*.

### 3.6 OPTIONAL CONTROL OUTPUTS

#### 3.6.1 Programming and adjustment

The BA368C timer can be supplied with two solid state, single pole control outputs. These may be independently programmed to open and close when various timer functions occur. See section 1.9.3 for details.

For simplicity Fig 3.4 shows the programmable functions for one control output. The second output is identical.

The following table summarises each of the control output programme functions and includes a cross reference to more detailed information. Again only the functions on control output 1 are listed.

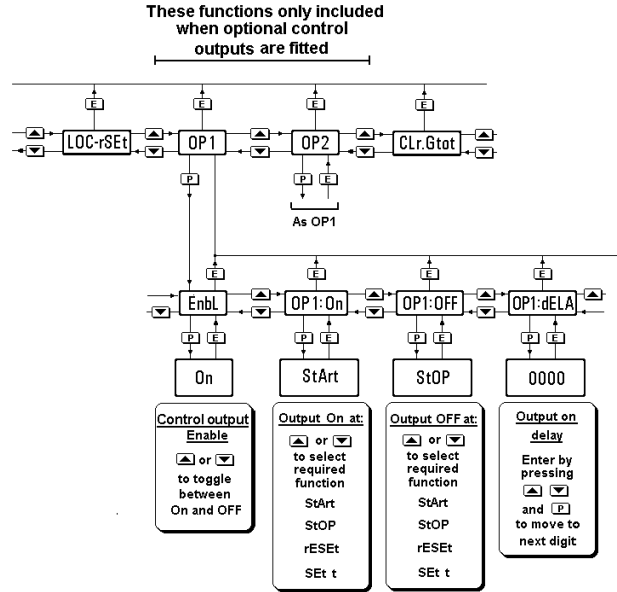

Fig 3.4 Control output sub-menu

#### Summary of programmable control output functions

<u>Display</u>	<u>Description of function</u>
'EnbL'	<b>Control output enable</b> Enables or disables the control output without changing the parameters. See section 3.6.2
'OP1:On'	<b>Output On at:</b> Defines when the control output turns on (closes). See section 3.6.3
'OP1:OFF'	<b>Output OFF at:</b> Defines when the control output turns off (opens). See section 3.6.4
'OP1:dELA'	<b>Output on delay time</b> Adjusts the delay between the specified on condition occurring and the control output being closed. See section 3.6.5

#### 3.6.2 Control output enable: 'EnbL'

This function allows the control output to be enabled or disabled without altering any other parameters. To check or change the function select 'EnbL' from the control output sub-menu and press *P* which will reveal the current setting. The function can be changed by pressing the *Up* or *Down* button followed by the *E* button to return to the control output sub-menu.

#### 3.6.3 Control output on at: 'OP1:On' and 'OP2:On'

The control outputs are very versatile and may be programmed to turn on (close) when the timer is started, stopped, reset or the elapsed time equals the programmed set time. To define when a control output closes select 'OP1:On' or 'OP2:On' from the control output sub-menu and press *P* which will reveal the current setting. Pressing the *Up* or *Down* button will scroll through the four options:

Display	Control output closes when
'StArt'	The timer is started
'StOP'	The timer is stopped
'rESEt'	The timer is reset
'SEt t'	The elapsed time equals set time setpoint SEt t.

When the required option has been selected press *E* to enter the selection and return to the control output sub-menu.

**Note:** When the timer elapsed time equals the set time SEt t, an internal stop signal is automatically generated and all actions associated with STOP are performed.



### 3.6.4 Control output off at: 'OP1:OFF' and 'OP2:OFF'

The control outputs may be programmed to turn off (open) when the timer is started, stopped, reset or the elapsed time equals the programmed set time. To define when a control output opens select 'OP1:OFF' or 'OP2:OFF' from the control output sub-menu and press *P* which will reveal the current setting. Pressing the *Up* or *Down* button will scroll through the four options:

Display	Control output closes when
'StArt'	The timer is started
'StOP'	The timer is stopped
'rESEt'	The timer is reset
'SEt t'	The elapsed time equals set time setpoint SEt t.

When the required option has been selected press *E* to enter the selection and return to the control output sub-menu.

**Note:** When the timer elapsed time equals the set time 'SEt t', an internal stop signal is automatically generated and all actions associated with STOP are performed.

### 3.6.5 Output on delay time: 'OP1:dELA' and 'OP2:dELA'

Both control outputs may be independently delayed from turning-on for a fixed time following the selected condition occurring. e.g. when the timer is started. This delay can be programmed in 1 second increments up to 32,400 seconds, which is 9 hours. If a delay is not required zero should be entered. To adjust the delay select 'dELA' from the control output sub-menu and press *P* which will reveal the existing delay time. Each digit of the delay can be adjusted using the *Up* and *Down* push-buttons, and the *P* button to move to the next digit. When the required delay has been entered, press *E* to return to the alarm menu.

When the delay function is used the front panel control output annunciator will start flashing when the programmed switching condition occurs. It will continue flashing until the delay time has expired, when the control output will close and the annunciator will be continuously activated.

## 3.7 APPLICATIONS

The BA368C timer is a versatile instrument which can perform a wide variety of hazardous area timing applications. BEKA engineers will be pleased to help with the design of your BA368C timing system be it a simple manually controlled stopwatch, or a more complicated control application.

Figure 3.5 shows how a BA368C timer may be used to measure how long a hazardous area contact is closed. This illustrates how the timer may be started and stopped by one input.

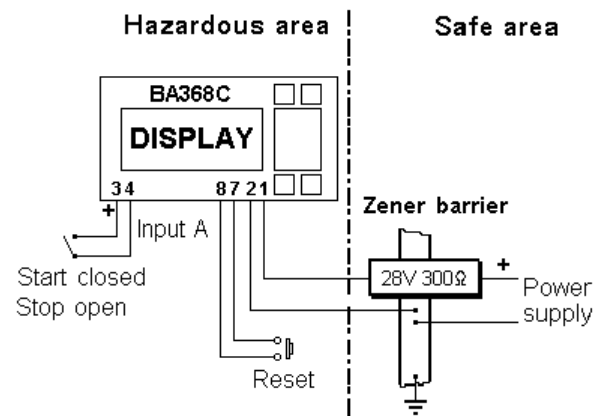

Fig 3.5 Starting & stopping timer with one input

The required programme parameters to achieve this are shown below, others are not critical.

FunCtion	'ELAPSE'	Timer
InPut A	'ContACt'	Switch contact
StArStOP	'Control 4'	Closure operates

The second example in Fig 3.6 shows how the timer may be configured to open an intrinsically safe solenoid valve for a defined time. When the start button is operated the timer starts to count up and control output 1 is closed which opens the solenoid valve. In this example the stop button functions as a pause control which closes the valve until the start button is again operated. When the total elapsed time equals the set time, 'SEt t', control output 1 opens thus closing the solenoid valve.

In this example control output 2 has been wired to the timer reset terminals and programmed with a five seconds control output delay. Therefore five seconds after the timing cycle has been completed the system automatically resets and is ready for the next timing cycle.

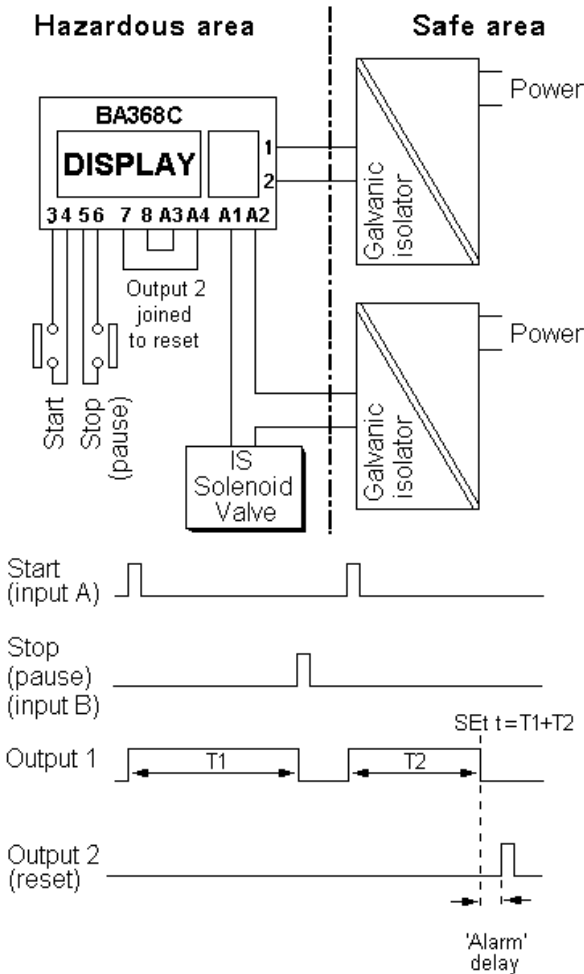

Fig 3.6 Control of valve in a hazardous area

The required programme parameters to achieve this are shown below, others, such as whether the second display is activated, are not critical.

FunCtion	'ELAPSE'	Timer
InPut A	'ContACt'	Switch contact
InPut b	'ContACt'	Switch contact
StArStOP	'Control 2'	Closure operates
SEt t		Time required
uP or dn	'uP'	Up counter
OP1		
EnbL	On	Enable control OP1
OP1:On	StArt	On when timer is started.
OP1:OFF	StOP	Off when timer is stopped.
OP1:dELA	00000	No delay required
OP2		
EnbL	On	Enable control OP2
OP2:On	SEt t	On at set time SEt t
OP2:OFF	rESEt	Off at rESEt
OP2:dELA	00005	5 second delay

**Note:** When the elapsed time (T1+T2) equals the set time SEt t, an internal stop signal is automatically generated which stops the timer and opens control output 1.

### 3.8 MAINTENANCE

#### 3.8.1 Fault finding during commissioning

If a BA368C timer fails to function during commissioning the following procedure should be followed:

Symptom	Cause	Check:
No display	Incorrect wiring Note: Terminals 2, 4, 6 & 8 are interconnected within the BA368C	That there is between 10 and 28V on terminals 1 & 2 with terminal 1 positive.
Timing cycle will not start Elapsed or remaining time display not changing	Incorrect programming or input wiring.	That instrument has been programmed as a timer for the transducer(s) in use, and that they are connected to the correct terminals with the correct polarity.
	Timer is being permanently reset.	That reset terminal 7 & 8 are not connected together.
	Stop input is activated.	Input at terminals 5 & 6
Timing cycle will not stop	Incorrect programming or input wiring	That SEt t has been programmed for the required cycle time.
No set time display	Lower display 'dISPLAY.2' not switched on.	Programming See 3.5.7
Control outputs do not function	Incorrect programming.	That control output is enabled and programmed to operate on required parameter. See 3.6.2 & 3.
Unable to enter programme mode	Incorrect security code.	That correct security code is being used, or fit security link in override position. See Fig 1.4

### 3.8.2 Fault finding after commissioning

#### ENSURE PLANT SAFETY BEFORE STARTING MAINTENANCE

**Live maintenance is permitted on intrinsically safe equipment installed in a hazardous area, but only certified test equipment should be used unless a gas clearance certificate is available.**

If a BA368C timer fails after it has been functioning correctly, the following table may help to identify the cause of the failure.

Symptom	Cause	Check:
No display	No power supply.	That there is between 10 and 28V on terminals 1 & 2.
Timing cycle will not start	Transducer or associated wiring has been damaged.	Presence of signal at input terminals.
	Timer is being permanently reset.	That reset terminals 7 & 8 are not connected together.
	Stop input is activated.	Input at terminals 5 & 6.
	Set time has expired but timer has not been reset.	Set time and reset timer.

If this procedure does not reveal the cause of the fault, it is recommended that the instrument is returned to BEKA associates or to our agent in your area for repair.

### 3.9 INDEX FOR TIMER SECTION

<b>Subject</b>	<b>Section</b>	<b>Subject</b>	<b>Section</b>
ATEX intrinsic safety certification	1.4; 3.2	Reset	
Backlight optional	1.9.6	Grand total	3.5.12
Calibration	3.5; Fig 3.3	Timer	3.3.3; 3.4.3 3.5.11
Controls	3.1.2	Security	
Control outputs optional	3.6	Code	3.5.13
Delay	3.6.5	Override link	1.6.1
Enable	3.6.2	Servicing	1.7
Intrinsic safety	1.9.3.2	Timer	
Output OFF	3.6.4	Direction	3.5.8
Output On	3.6.3	Resetting	3.3.3; 3.4.3 3.5.11
Solid state outputs	1.9.3.1	Set time	3.5.6
Display	3.1.3	Access	3.5.7
Lower	3.5.9	Display	3.5.9
Resetting timer	3.3.3; 3.4.3 3.5.11	Starting & stopping	3.5.4
Function of instrument	3.5.2	Units of display	3.5.5
Grand total	3.1	Zener barriers use with	3.3
Resetting	3.5.12		
Guarantee	1.7.2		
Galvanic isolator use with	3.4		
Input	3.5.3		
Installation	1.5		
Location	1.5.1		
Loss of power	3.5.10		
Maintenance	3.8		
Routine	1.7.1		
Power supply	3.3.1; 3.4.1		

## Section 4

### Use as a Tachometer

- 4.1 Description**
  - 4.1.1 Initialisation & loss of power
  - 4.1.2 Controls
  - 4.1.3 Displays
- 4.2 System certificates**
- 4.3 Use with Zener barriers**
  - 4.3.1 Power supply
  - 4.3.2 Input
  - 4.3.3 Resetting the run-time display
  - 4.3.4 Optional 4/20mA output
  - 4.3.5 Optional alarm outputs
- 4.4 Use with galvanic isolators**
  - 4.4.1 Power supply
  - 4.4.2 Input
  - 4.4.3 Resetting the run-time display
  - 4.4.4 Optional 4/20mA output
  - 4.4.5 Optional alarm outputs
- 4.5 Programming**
  - 4.5.1 Accessing programme functions
  - 4.5.2 Function of instrument
  - 4.5.3 Type of input
  - 4.5.4 Position of decimal point
  - 4.5.5 Lower display
  - 4.5.6 Rotational scale factor
  - 4.5.7 Timebase
  - 4.5.8 Display filter
  - 4.5.9 Clip off
  - 4.5.10 Local reset of run-time display
  - 4.5.11 Resetting run-time grand total
  - 4.5.12 Security code
- 4.6 Optional Alarms**
  - 4.6.1 Programming and adjustment
  - 4.6.2 Alarm enable
  - 4.6.3 Type of alarm
  - 4.6.4 Setpoint adjustment
  - 4.6.5 Alarm function
  - 4.6.6 Alarm output status
  - 4.6.7 Hysteresis
  - 4.6.8 Alarm delay
  - 4.6.9 Alarm silence time
  - 4.6.10 Access setpoint
  - 4.6.11 Adjusting setpoints from display mode.
- 4.7 Optional 4/20mA output**
  - 4.7.1 Programming & adjustment
- 4.8 Calibration example**
- 4.9 Maintenance**
  - 4.9.1 Fault finding during commissioning.
  - 4.9.2 Fault finding after commissioning.
- 4.10 Index for Tachometer section**

#### 4.1 DESCRIPTION

When programmed as a tachometer the BA368C will display rotational speed in revolutions per second, minute or hour. Linear speed in engineering units may also be displayed. To assist with routine maintenance, a run-time clock records the number of hours the monitored machinery has been operating. The displayed run-time may be reset to zero from the instrument front panel, or by closure of a remote contact. The instrument also maintains a grand total run-time which can only be reset from within the programme menu.

An optional 4/20mA output current sink may be programmed to produce a linear output proportional to any part of the displayed speed range.

Two optional alarm outputs may be programmed to provide speed warnings, or from the run-time display to indicate when routine maintenance is due.

##### 4.1.1 Initialisation and loss of power

When power is applied to a BA368C tachometer, following initialisation the instrument will start functioning using the programmed parameters. If during operation the power supply is interrupted, all programme parameters and the run-time will be stored in permanent memory.

##### 4.1.2 Controls

The BA368C tachometer is controlled and calibrated via four front panel push-button switches. In the display mode i.e. when the instrument is displaying speed the switch functions are:

#### Description of Switch Functions

**E+Down** While these buttons are pushed the speed display will show the run-time grand total and the grand total annunciator will be activated.

**Down +Up** Resets the run-time display to zero when these two push-buttons are operated simultaneously for more than two seconds. Selectable function from programme menu. See section 4.5.10

**P+Down** While these buttons are pushed the instrument will display the firmware and version numbers plus the programmed function.

**Note:** When optional alarms are fitted, the BA368C may be programmed to provide direct access to the alarm setpoints from the display mode by operating the *P + Up* push-buttons. See section 4.6.10

##### 4.1.3 Displays

The BA368C tachometer has two digital displays and associated annunciators, plus a pulse input indicator.

<b>Speed display</b>	Shows speed on the larger six digit display.
<b>Run-time display</b>	Shows the time that monitored machinery has been operating on smaller six digit display. May be turned off – see 4.5.5
<b>Pulse input indicator</b>	This disc in the lower left hand corner of the display 'rotates' for two seconds each time an input pulse is received. Therefore when the pulse input frequency exceeds 0.5Hz the disc appears to rotate continuously.
<b>Reset Annunciator</b>	Activated while run-time display is being reset to zero.
<b>Hold Annunciator</b>	Activated when input frequency is below the clip-off threshold at which the run-time clock stops operating.
<b>Grand total Annunciator</b>	Activated while run-time grand total is being displayed.
<b>Alarm Annunciators</b>	Activated when optional alarm is activated

#### 4.2 SYSTEM CERTIFICATES

In addition to the ATEX EC-Type Examination Certificate, ITS have issued two system certificates. One defines how the BA368C may be used with Zener barriers and the other with galvanic isolators.

Interface	Certificate No
Zener barriers	Ex01E2007
Galvanic isolators	Ex01E2008

This section interprets these system certificates and illustrates how to design tachometer systems with Zener barriers and galvanic isolators.

System certificates are Certificates of Conformity which are primarily issued for guidance in the UK. They do not form part of certification to the European ATEX Directive.

### 4.3 USE WITH ZENER BARRIERS

Zener barriers are the least expensive intrinsically safe interface between a safe and hazardous area. However, they do not provide isolation and require a high integrity earth connection that may be expensive to install. For a single BA368C totaliser it may be less expensive and complicated to use galvanic isolators when a high integrity earth connection is not already available.

Any certified Zener barriers may be used with the BA368C providing their output parameters do not exceed the input parameters of the terminals to which they are connected. Only one polarity of Zener barrier i.e. positive or negative, may be used with each instrument.

To assist with system design, the Zener barrier system certificate specifies the maximum output parameters of the Zener barriers that may be connected to the BA368C and defines the maximum cable parameters. Diode return barriers are identified by manufacturers type number, although alternatives may be used.

The basic system used for all BA368C hazardous area clock installations is shown in Fig 4.1 Intrinsic safety requirements are explained in section one of this manual which should be read before the system is designed.

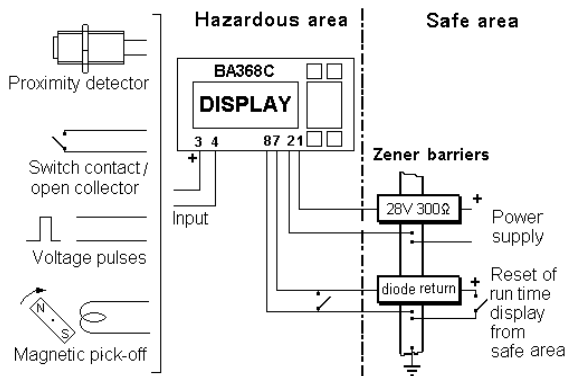

Fig 4.1 Tachometer installation using barriers

If the run-time display is not used, or is reset from the instrument front panel only the power supply Zener barrier is required.

#### 4.3.1 Power supply

A BA368C is powered from the safe area via a positive polarity 28V 300Ω Zener barrier which will have an end-to-end resistance of about 340Ω. When operating as a tachometer the BA368C consumes approximately 15mA and requires a minimum voltage of 10V between terminals 1 and 2. The supply voltage in the safe area must therefore be between 16V and the maximum working voltage of the Zener barrier – usually about 26V.

#### 4.3.2 Input

When the BA368C is programmed as a tachometer only input A is operational. This input may be programmed to operate with almost any pulse output transducer.

The following table shows the switching thresholds for the various transducers, plus the maximum operating frequency and the input terminal numbers. For reliable counting the input signal must fall below the lower threshold and rise above the upper threshold.

Switch	Switching thresholds		Freq max	Input terminals
	100Ω	1000Ω		
Proximity detector	1.2mA	2.1mA	5kHz	3 & 4
Open collector	2kΩ	10kΩ	5kHz	3 & 4
Magnetic pick-off	0mV	20mV peak	5kHz	3 & 4
Voltage pulse	1.0V	3.0V	5kHz	3 & 4

The intrinsic safety requirements are explained in section 1.4.3 Almost any mechanically or magnetically activated switch, or intrinsically safe NAMUR 2-wire proximity detector may be directly connected to the input terminals.

If the BA368C is located in a hazardous area but the transducer is in a safe area, a Zener barrier is required to transfer the transducer output to the instrument. The system certificate defines barriers which may be used.

#### 4.3.3 Resetting the run-time display

When terminals 7 & 8 are connected together the run-time display will be reset to zero. To achieve reliable resetting the contacts must close for at least one second.

Resetting may be accomplished by any mechanically operated switch located in the hazardous area providing it can withstand a 500V rms insulation test to earth for one minute. No Zener barrier is required.

The BA368C may also be reset from within the safe area. Any switch may be used but a Zener barrier is required to transfer the contact closure into the hazardous area. A diode return barrier combined with the supply barrier so that only one dual channel device is required is an economic solution. The system certificate lists some of devices that may be used.

Fig 4.1 illustrates how the BA368C tachometer run-time display may be reset from both the safe and the hazardous area.

#### 4.3.4 Optional 4/20mA output

The BA368C can be supplied with an isolated 4/20mA current sink which may be programmed to produce an analogue output proportional to any part of the speed display. See section 4.7

#### 4.3.5 Optional alarm outputs

The BA368C can be supplied with two isolated solid state alarm outputs which may be independently programmed as high or low, speed or run-time alarms with normally open or normally closed outputs. These outputs may be used to switch certified intrinsically safe devices within the hazardous area, or the contacts may be transferred to the safe area via a Zener barrier. See section 4.6

### 4.4 USE WITH GALVANIC ISOLATORS

Galvanic isolators are probably the easiest intrinsically safe interface to use as they provide isolation and do not require a high integrity earth connection.

Any EEx ia IIC certified intrinsically safe galvanic isolators may be used with the BA368C providing the output parameters do not exceed the input parameters of the terminals to which they are connected.

To assist with system design, the galvanic isolator system certificate lists the isolators that may be used and defines the maximum permitted cable parameters.

Fig 4.2 illustrates the basic circuit that is used for all BA368C tachometer installations protected by galvanic isolators. Intrinsic safety requirements are explained in section one of this manual which should be read before the system is designed.

If the run-time display is not used, or is reset from the instrument front panel only the power supply galvanic isolator is required.

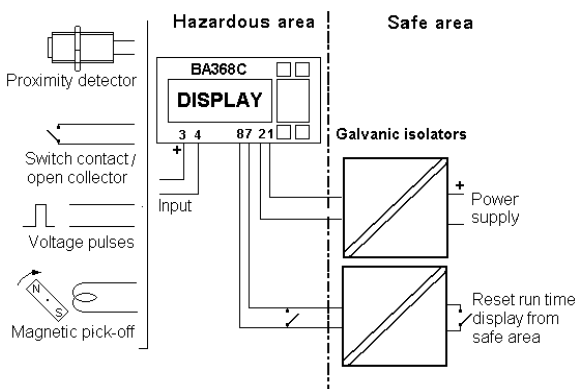

Fig 4.2 Basic tachometer circuit using isolators

#### 4.4.1 Power supply

The BA368C galvanic isolator system certificate lists a wide range of certified galvanic isolators that may be used to power the instrument. If using the entity concept to select an isolator, in addition to matching the safety parameters, the isolator must be capable of supplying 10V dc minimum at 15mA to the BA368C.

#### 4.4.2 Input

When the BA368C is programmed as a tachometer only input A is operational. This input may be programmed to operate with almost any pulse output transducer.

The following table shows the switching thresholds for the various transducers, plus the maximum operating frequency and the input terminal numbers. For reliable counting the input signal must fall below the lower threshold and rise above the upper threshold.

	Switching thresholds		Freq max	Input terminals
	Lower	Upper		
Switch	100Ω	1000Ω	100Hz	3 & 4
Proximity detector	1.2mA	2.1mA	5kHz	3 & 4
Open collector	2kΩ	10kΩ	5kHz	3 & 4
Magnetic pick-off	0mV	20mV peak	5kHz	3 & 4
Voltage pulse	1.0V	3.0V	5kHz	3 & 4

The intrinsic safety requirements are explained in section 1.4.3. Almost any mechanically or magnetically activated switch, or intrinsically safe NAMUR 2-wire proximity detector may be directly connected to the input terminals.

If the BA368C is located in a hazardous area but the transducer is in a safe area, a galvanic isolator is required to transfer the transducer output to the instrument. The system certificate defines devices which may be used.



#### 4.4.3 Resetting the run-time display

When activated the run-time display can be reset to zero by connecting terminals 7 & 8 together. To achieve reliable resetting the contacts must close for at least one second.

Resetting may be accomplished by any mechanically operated switch located in the hazardous area providing it can withstand a 500V rms insulation test to earth for one minute. No galvanic isolator is required.

The BA368C may also be reset from within the safe area. Any switch may be used, but a galvanic isolator or intrinsically safe relay is required to transfer the contact closure into the hazardous area. See system certificate for a list of some devices that may be used. Fig 4.2 illustrates how the BA368C may be reset from both the safe and the hazardous area.

#### 4.4.4 Optional 4/20mA output

The BA368C can be supplied with an isolated 4/20mA current sink which may be programmed to produce an analogue output proportional to any part of the speed display. See section 4.7

#### 4.4.5 Optional alarm outputs

The BA368C can be supplied with two isolated solid state switch alarm outputs which may be independently programmed as high or low, speed or run-time alarms with normally open or closed outputs. These outputs may be used to switch certified intrinsically safe devices within the hazardous area, or the contacts may be transferred to the safe area via a galvanic isolator. See section 4.6

### 4.5 PROGRAMMING

Throughout this manual push-buttons are shown in italics e.g. *P* or *Up* push-button, and legends displayed by the instrument are shown within inverted commas e.g. 'SEt' and 'dISPLAY'.

#### 4.5.1 Accessing programme functions

Access to the programme menu is obtained by operating the *P* and *E* push-buttons simultaneously. If the BA368C is not protected by a security code the first parameter 'Function' will be displayed. If a security code other than the default code 0000 has already been entered, the instrument will display 'COdE'. Press *P* to clear this prompt and enter the security code for the instrument using the *Up* or *Down* push-button to adjust each digit, and the *P* push-button to move control to the next digit. If the correct code has been entered pressing *E* will cause the first parameter 'Function' to be displayed. If an incorrect code is entered, or a push-button is not operated within ten seconds, the instrument will automatically return to the display mode.

Once within the main programme menu the required parameter can be reached by scrolling through the menu using the *Up* and *Down* push-buttons as shown by the tachometer programme structure shown in Fig 4.3.

This section summarises all the tachometer programmable parameters excluding the optional alarms and 4/20mA output. When read in conjunction with Fig 4.3 it provides a quick aid for programming the instrument. If more detail is required, each section contains a reference to a full description of the function.

Programming details for the alarms and 4/20mA output are contained in sections 4.6.1 and 4.7

**SUMMARY**

<u>Display</u>	<u>Description of function</u>
<b>'Function'</b>	<p><b>Function of instrument</b> Enables the BA368C to be conditioned as a counter, timer, tachometer or clock. After making the selection 'SurE' has to be entered to confirm the instruction. Select 'tACHO' to enable the tachometer functions. See section 4.5.2</p>
<b>'InPut A'</b>	<p><b>Type of input</b> Conditions input A to work with one of five types of transducer: 'UOLtS' Voltage pulse 'COIL' Magnetic pick-off 'Pr.dEt' NAMUR proximity detector. 'COntACt' Switch contact 'OP.COL' Open collector See section 4.5.3</p>
<b>'d.P.'</b>	<p><b>Position of decimal point</b> Defines the position of the decimal point in speed display. <b>Note:</b> The run-time display has a fixed decimal point to give resolution of 0.1 hours. See section 4.5.4</p>
<b>'dISPLAY.2'</b>	<p><b>Lower display (run-time)</b> Turns the lower six digit display, which shows the run-time, on or off. See section 4.5.5</p>
<b>'r SCALE'</b>	<p><b>Rotational scale factor</b> Dividing factor that compensates for the number of pulses the transducer produces per revolution. May be adjusted between 0.001 and 99999999. See section 4.5.6</p>
<b>'t-bASE'</b>	<p><b>Timebase</b> Selectable multiplier to display rotational speed in revolutions per second, per minute or per hour. Select: tb-1 for revs. / second tb-60 for revs. / minute tb-3600 for revs. / hour See section 4.5.7</p>

<u>Display</u>	<u>Description of function</u>
<b>'FILtEr'</b>	<p><b>Display filter</b> Adjustable digital filter to reduce noise on the speed display. Adjustable between 0 and 99. See section 4.5.8</p>
<b>'CLIP-OFF'</b>	<p><b>Clip-off</b> Sets the displayed speed threshold below which the run-time display does not operate. See section 4.5.9</p>
<b>'LOC-rSET'</b>	<p><b>Local reset of run-time display</b> When turned 'On' the run-time display may be reset to zero from the display mode by simultaneously operating the <i>Up</i> and <i>Down</i> push-buttons for at least two seconds. See section 4.5.10</p>
<b>'CLr.Gtot'</b>	<p><b>Clear grand total</b> This function resets the run-time grand total to zero when 'CLr YES' is selected, and 'SurE' is entered to confirm the instruction. <b>Note:</b> Once cleared, a grand total can not be recovered. See section 4.5.11</p>
<b>'COdE'</b>	<p><b>Security code</b> Defines a four digit numeric code which must be entered to gain access to the programmable functions. Default code 0000 disables the security function and allows unrestricted access to all programmable functions. See section 4.5.12</p>

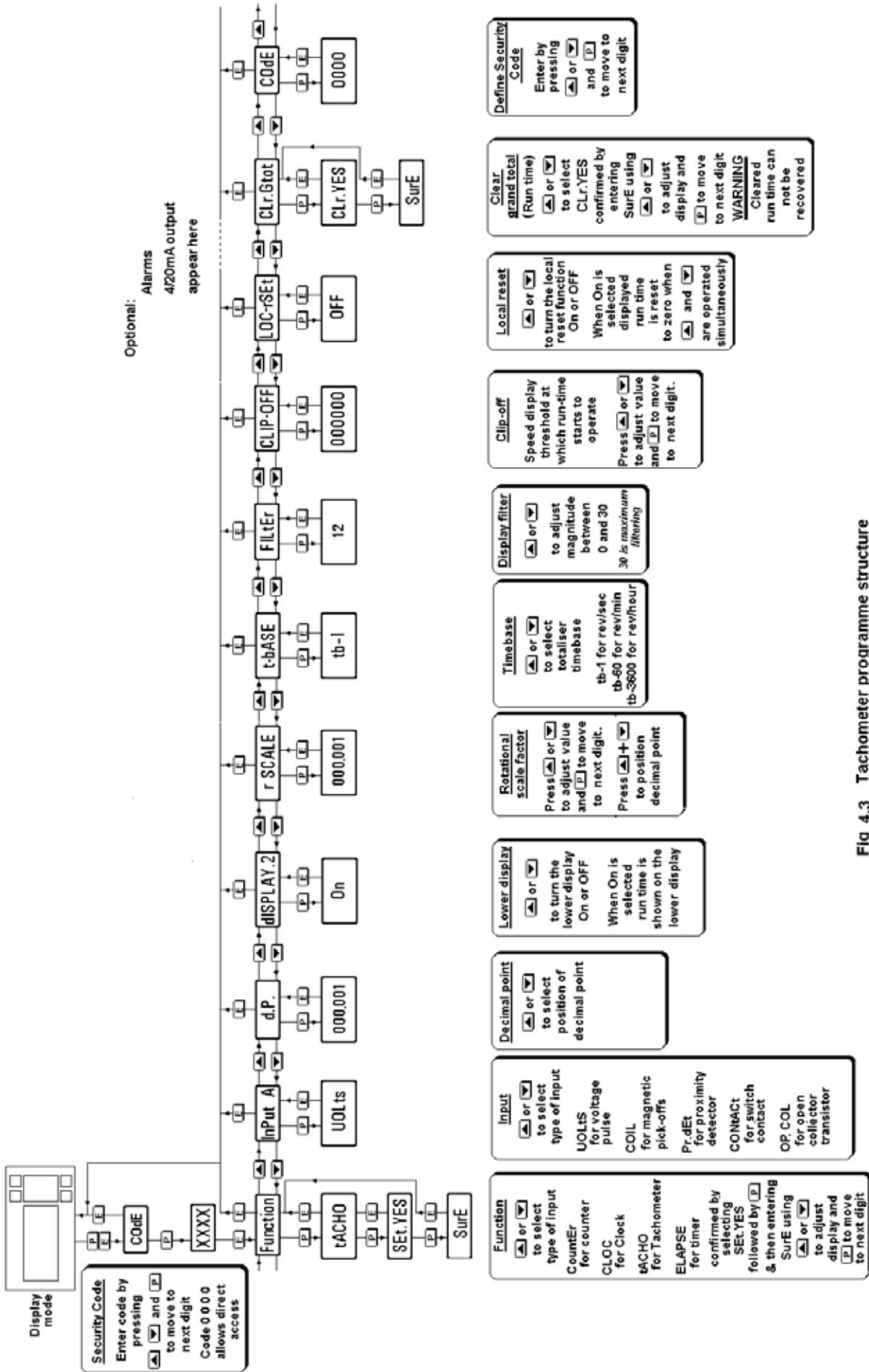

Fig 4.3 Tachometer programme structure

#### 4.5.2 Function of instrument: 'Function'

This is the first function in the programme menu which conditions the instrument as a counter, timer, tachometer or as a clock.

##### CAUTION

**This function must be entered before any of the other parameters are programmed. It is protected by a password to prevent accidental changes.**

To define the function of the instrument select 'Function' from the main menu and press *P* which will reveal the existing setting. Pressing the *Up* or *Down* button will scroll through the four options:

Display	Instrument function
'CountEr'	Counter
'CLOC'	Clock
'tACHO'	Tachometer
'ELAPSE'	Timer

When 'tACHO' is displayed, press *P* which will result in 'Set.nO' being displayed. To proceed press *Up* or *Down* which will change this to 'Set.YES'. To confirm the function change, press *P* which will result in prompt 'Set 0000' with one digit flashing. Using the *Up*, and *Down* buttons and the *P* button to move to the next digit, enter the password 'SurE'. Note 'S' is entered as '5'. Finally, pressing *E* will execute the change to a tachometer and return the display to the 'Function' prompt in the main menu.

#### 4.5.3 Type of input: 'InPut A'

To define an input type select 'InPut A' from the menu and press *P*, which will reveal the current input type. Pressing the *Up* or *Down* button will scroll through the five options:

'UOLts'	Voltage input Threshold 1V and 3V 5kHz max.
'COIL'	Low voltage Threshold 20mV peak 5kHz max.
'Pr.dEt'	NAMUR proximity detector Threshold 1.2 and 2.1mA 5kHz max.
'COntAct'	Switch contact Threshold 100 and 1000Ω 100Hz max
'OP.COL'	Open collector Threshold 2kΩ and 10kΩ 5kHz max.

When the required type of input has been selected press *E* to enter the selection and return to the 'InPut A' prompt in the main menu.

**Note:** To count reliably, the input signal must fall below the lower switching threshold and rise above the higher switching threshold.

#### 4.5.4 Position of the decimal point: 'd.P.'

The BA368C speed display has six digits and the decimal point may be positioned between any of them, or may be omitted.

To adjust the position of the decimal point select 'd.P.' from the main menu and press *P*. This will activate the display with one digit plus the following decimal point flashing. If only the least significant digit is flashing the decimal point will be omitted. The position of the decimal point can be moved by pressing the *Up* or *Down* push-button.

When the decimal point is positioned correctly press *E* to return to the main menu.

**Note:** The run-time display has a fixed decimal point to give resolution of 0.1 hours.

#### 4.5.5 Lower display: 'DISPLAY.2'

This function turns the lower display, which shows the run-time, on or off. When turned off the BA368C will just display speed, when turned on the instrument will display speed and the run-time simultaneously.

To check the status of the lower display select 'DISPLAY.2' from the menu and press *P* which will reveal if the function is 'On' or 'OFF'. If necessary press the *Up* or *Down* button to change the setting, followed by the *E* button to return to the main menu.

#### 4.5.6 Rotational scale factor: 'r SCALE'

This function together with the timebase 't-BASE' defines the arithmetic relationship between the pulse input frequency from the rotary transducer and the BA368C speed display.

'r SCALE' is a dividing factor that may be adjusted between 0.001 and 99999999. It compensates for the number of pulses the transducer produces per revolution. It may also be used to produce a display in other engineering units such as hundreds of revolutions or in linear units such as metres per minute.

To check or change the scale factor select 'r SCALE' from the main menu and press *P* to reveal the existing setting, one digit will be flashing. The value of the flashing digit can be changed by pressing the *Up* or *Down* buttons. When this digit is correct pressing *P* will transfer control to the next digit.

To position the decimal point in the scale factor, move the flashing digit to the left hand side of the required decimal point position and simultaneously press the *Up* and *Down* buttons.

When the required scale factor has been entered, press *E* to store the number and return to the main menu.

#### 4.5.7 Timebase: 't-bASE'

This function multiplies the speed display by 1, 60 or 3,600 to show revolutions per second, minute or hour.

To check or change the timebase, select 't-bASE' from the main menu and press *P* which will reveal the current setting. Pressing the *Up* or *Down* button will scroll through the three options:

Display	Units
tb-1	for speed / second
tb-60	for speed / minute
tb-3600	for speed / hour

When the required timebase is displayed press *E* to enter the selection and return to the main menu.

#### 4.5.8 Display filter: 'FILtEr'

This digital filter has two independent adjustable parameters enabling the speed display frequency response to be tailored for optimum performance.

The filter parameters are controlled by a two digit number. The first digit defines the amount of filtering applied to the display as shown below.

First digit	Filter time constant seconds
0X	0
1X	1.3
2X	4.3
3X	6.5
4X	8.7
5X	11.3
6X	15.7
7X	20.9
8X	25.2
9X	31.5

The second digit defines the deviation from the displayed rate at which the filter will be overridden and the speed display will move rapidly to the new value.

Second digit	Magnitude of step change which will produce a rapid response
X0	Off
X1	1%
X2	2%
X3	4%
X4	8%
X5	12%
X6	16%
X7	24%
X8	32%
X9	64%

By careful adjustment of the two parameters a stable display with an acceptable step input response can be obtained for most applications.

During commissioning it is recommended that initially the second digit is set to 0 (off) and the first digit is adjusted to provide acceptable speed display stability. The second digit should then be increased until the selected step size is greater than the noise on the speed signal, at which setting the speed display will again become stable. These will be the optimum filter parameters for acceptable speed display stability and a fast response to a large speed signal change.

To check or change the filter select 'FILtEr' from the main menu and press *P* to reveal the current settings. Pressing the *Up* or *Down* button will change the flashing digit and *P* will transfer control to the second digit. While making adjustments the filtered speed display is shown on the lower display so that stability can be assessed. When set as required, press the *E* button to enter the revised parameters and return to the main menu.

#### 4.5.9 Clip off: 'CLIP-OFF'

Clip off defines the speed threshold above which the monitored machine is assumed to be working and the run-time clock is activated.

To check or change the clip-off threshold select 'CLIP-OFF' from the main menu and press *P* which will reveal the current setting. The threshold is shown in the units already selected for the speed display. One digit will be flashing. The value of the flashing digit may be changed by pressing the *Up* or *Down* buttons. When this digit is correct pressing *P* will transfer control to the next digit. When clip-off is set as required, press the *E* button to enter the revised figure and return to the main programme menu.

When the displayed speed falls below the entered threshold, the speed display will show zero, the run-time clock will be stopped and the 'HOLD' annunciator will be activated. The pulse input indicator will continue to rotate until the input pulse frequency falls below 0.5Hz i.e. 2 seconds between input pulses.

**Note:** When the rotational scale factor 'r-SCALE', the timebase 't-bASE', or the position of the speed display decimal point are changed, clip-off will automatically be reset to zero. If required, a new clip-off threshold must then be entered.

#### 4.5.10 Local reset of run-time display: 'LOC- rSET'

This function allows the local reset of the run-time display to be turned on or off. When turned on, operating the *Up* and *Down* push-buttons simultaneously for more than two seconds in the display mode will reset the run-time display to zero. This allows the operator to reset the run-time while the instrument is displaying speed.

To check the status of the local reset function select 'LOC-rSET' from the menu and press *P* which will reveal if the function is 'On' or 'OFF'. If necessary press the *Up* or *Down* button to change the setting, followed by the *E* button to return to the main menu.

The run-time display may also be reset to zero remotely by connecting terminals 7 and 8 together. See Figs 4.1 and 4.2

#### 4.5.11 Resetting run-time grand total: 'CLr. Gtot'

The grand total is a separate eight digit counter which duplicates the run-time display, but is not cleared when the run-time display is reset to zero.

The grand total run-time may be viewed when the instrument is in the display mode by operating the *E* and *Down* push-buttons simultaneously.

The grand total can only be reset to zero from the 'CLr. Gtot' function in the main programme menu. To zero the grand total select 'CLr. Gtot' and press *P* which will cause the instrument to display 'CLr. no' with 'no' flashing. Continuously press the *Up* or *Down* push-buttons until 'CLr. YES' is displayed and then press *P* which will result in a 'CLr. 0000' prompt with one digit flashing. Using the *Up*, and *Down* buttons and the *P* button to move to the next digit, confirm the request by entering the password 'SurE'. Note 'S' is entered as '5'. Pressing *E* will then reset the grand total counter to zero and return the instrument to the 'CLr. Gtot' prompt in the main menu.

### WARNING

**After resetting the grand total to zero the old grand total can not be recovered.**

#### 4.5.12 Security code: 'CodE'

The calibration and conditioning of the BA368C may be protected by a four digit security code which must be entered before access to the programme menu is allowed. New instruments are programmed with the default security code 0000 that allows unrestricted access to all programming functions without entering a security code.

To enter a new security code select 'COdE' from the menu and press *P* which will cause the instrument to display the current security code. Each digit of the code can be changed using the *Up* and *Down* push-buttons, and the *P* button to move to the next digit. When the required code has been entered press *E* to return to the main menu. The revised security code will be activated when the instrument is returned to the display mode.

If the security code is lost, access to the programmable functions can be obtained by moving the internal security link to the override position as shown in section 1.6.1. The original security code can then be viewed by selecting 'COdE' from the main menu and pressing *P*.

## 4.6 OPTIONAL ALARMS

### 4.6.1 Programming and adjustment

The BA368C can be supplied with two solid state single pole alarm outputs which may be independently programmed as high or low, speed or run-time alarms with normally open or normally closed outputs. See section 1.9.3 for details.

For simplicity Fig 4.4 only shows the programmable functions for one alarm output. The second output is identical.

The following table summarises each of the alarm programme functions and includes a cross reference to more detailed information. Again only the functions on alarm AL1 are listed.

#### Summary of programmable alarm functions

<u>Display</u>	<u>Description of function</u>
'EnbL'	<p><b>Alarm enable</b> Enables or disables the alarm function without changing the alarm parameters. See section 4.6.2</p>
'tYPE'	<p><b>Type of alarm</b> Defines whether the alarms operate on the speed or the run-time display. See section 4.6.3</p>
'SPS1' or 'SPh1'	<p><b>Alarm setpoint 1</b> Adjusts the alarm setpoint. The alarm is activated when the display equals the setpoint. 'SPS1' is displayed when a speed alarm has been selected, and 'SPh1' is displayed for a run-time alarm. See section 4.6.4</p>
'HI.LO'	<p><b>Alarm function</b> Defines whether the alarm has a high or low function See section 4.6.5</p>
'no.nc'	<p><b>Normally open or normally closed output</b> Determines whether the single pole alarm output is open or closed in the non-alarm condition. See section 4.6.6</p>
'HStr'	<p><b>Hysteresis</b> Adjusts the alarm hysteresis. Only available for speed alarms. See section 4.6.7</p>

<u>Display</u>	<u>Description of function</u>
'dELA'	<p><b>Alarm delay time</b> Adjusts the delay between the display equalling the setpoint and the alarm output being activated. See section 4.6.8</p>
'SIL'	<p><b>Alarm silence time</b> Defines the time that the alarm output remains in the non-alarm condition following acceptance of an alarm. See section 4.6.9</p>
'AcSP'	<p><b>Access setpoint</b> Sub-menu that enables direct access to the alarm setpoints from the display mode and defines a separate security code. See section 4.6.10</p>

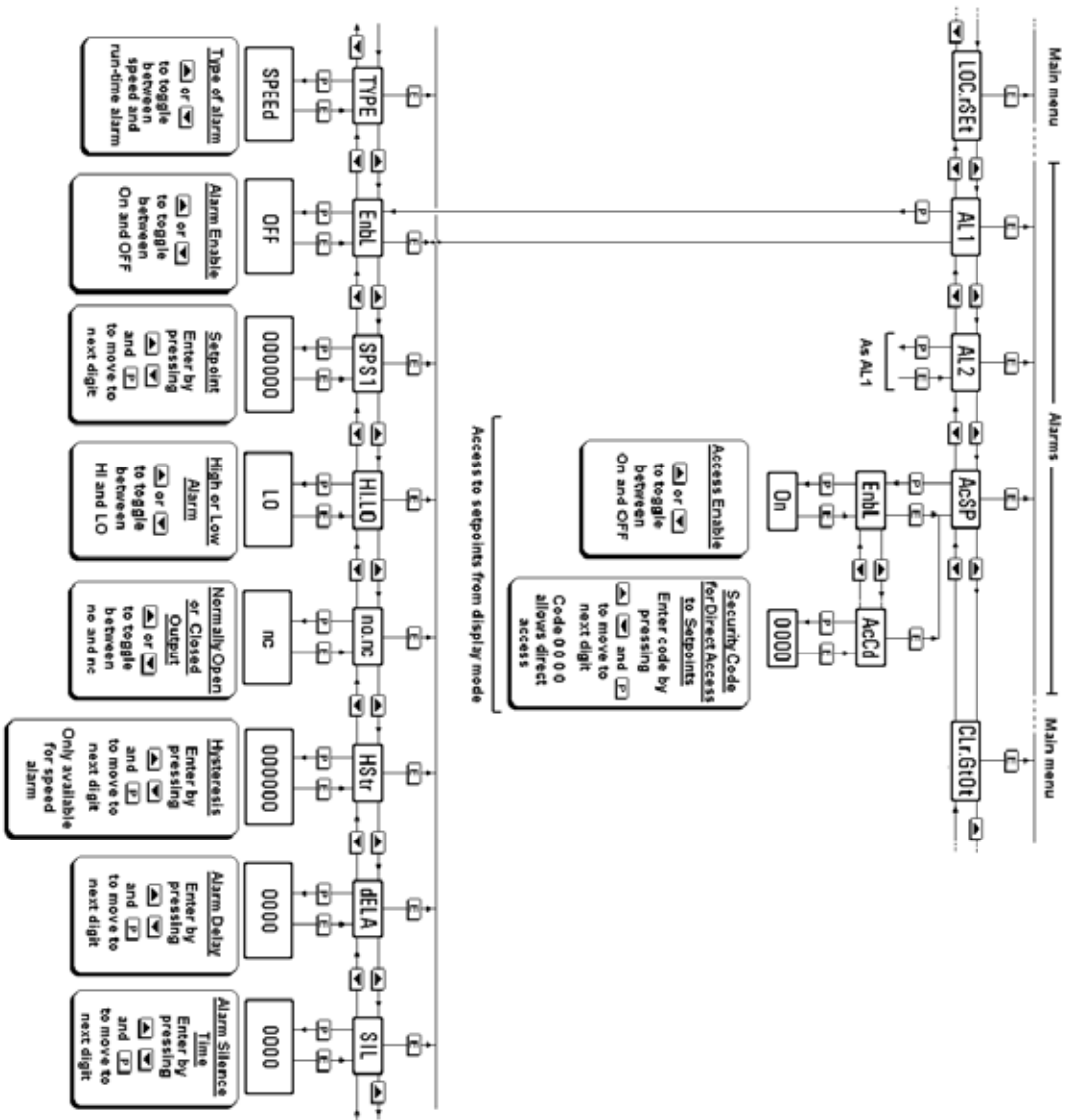

Fig 4.4 Programme structure for optional tachometer alarms



#### 4.6.2 Alarm enable: 'EnbL'

This function allows the alarm output to be enabled or disabled without altering any other parameters. To check or change the function select 'EnbL' from the alarm menu and press *P* which will reveal the current setting. The function can be changed by pressing the *Up* or *Down* button followed by the *E* button to return to the alarm menu.

#### 4.6.3 Type of alarm: 'tYPE'

The 'tYPE' function conditions the alarm to operate from the speed or run-time displays.

To check or change the type of alarm, select 'tYPE' from the alarm menu and press *P* which will reveal the current setting, 'SPEEd' or 'hourS'. The function can be changed by pressing the *Up* or *Down* button followed by the *E* button to return to the alarm menu.

**Note:** When 'tYPE' is changed, the alarm parameters are automatically set to the default values and the alarm is disabled. It must therefore be reprogrammed before use.

#### 4.6.4 Setpoint adjustment: 'SPS1' or SPh1'

The setpoint, which is displayed in the units and format selected when the instrument was programmed, may be positioned anywhere in the instrument display range. To adjust the setpoint of alarm 1 select 'SPS1' or 'SPh1' from the main menu. 'SPS1' is displayed when a speed alarm has been selected and 'SPh1' when a run-time alarm has been selected. Pressing *P* will reveal the existing setpoint value with one digit flashing. Each digit may be adjusted using the *Up* and *Down* push-buttons and the *P* button will transfer control to the next digit. When set as required, pressing *E* will return the display to the alarm menu.

#### 4.6.5 Alarm function: 'HI.LO'

Each alarm may be conditioned as a high or low alarm. To check or change the alarm function select 'HI.LO' from the alarm menu and press *P* to reveal the current setting. The function can be changed by pressing the *Up* or *Down* buttons followed by the *E* button to return to the alarm menu.

#### 4.6.6 Alarm output status: 'no.nc'

The alarm output may be open or closed in the non-alarm condition. When the BA368C power supply is turned off or disconnected, both the alarm outputs will open irrespective of whether normally open or normally closed outputs have been selected. Therefore an open output should be the alarm condition for fail-safe operation.

To check the alarm output status select 'no.nc' from the alarm menu and press *P* to reveal the current setting. The function can be changed by pressing the *Up* or *Down* button followed by the *E* button to return to the alarm menu.

#### 4.6.7 Hysteresis: 'HStr'

Hysteresis is only available when the alarm has been conditioned as a speed alarm. During programming hysteresis is shown in the units that the instrument has been calibrated to display.

To adjust the hysteresis, select 'HStr' from the alarm menu and press *P* to reveal the existing figure. Each digit can be adjusted using the *Up* and *Down* push-buttons. The *P* button transfers control to the next digit. When the required hysteresis has been entered, press *E* to return to the alarm menu.

e.g. When calibrated to display rotary speed with a high alarm at 4000 and hysteresis of 100, the alarm will perform as follows:

High alarm will be activated when speed equals or exceeds 4000rpm, but will not reset until the speed falls below 3900rpm.

#### 4.6.8 Alarm delay: 'dELA'

The alarm output may be delayed for a fixed time following the alarm condition occurring. The delay can be programmed in 1 second increments up to 3600 seconds. If a delay is not required zero should be entered. To adjust the delay select 'dELA' from the alarm menu and press *P* which will reveal the existing delay time. Each digit of the delay can be adjusted using the *Up* and *Down* push-buttons, and the *P* button to move to the next digit. When the required delay has been entered, press *E* to return to the alarm menu.

The front panel alarm annunciator will start flashing immediately an alarm occurs and continue for the delay time after which the alarm output will be activated.

#### 4.6.9 Alarm silence time: 'SIL'

This is primarily intended for use in small installations where the alarm output directly operates an annunciator such as a sounder. When the alarm silence time is set to any figure other than zero, the *P* push-button becomes an alarm accept button.

After an alarm has occurred, operating the *P* button will cause the alarm output to revert to the non-alarm condition for the programmed alarm silence time.

When an alarm is silenced the BA368C front panel alarm annunciator will flash until the silence time expires.

To adjust the silence time select 'SIL' from the alarm menu and press *P* which will reveal the existing time. The time may be adjusted to between 0 and 3600 seconds in 1 second increments. Each digit can be adjusted using the *Up* and *Down* push-buttons, and the *P* button transfers control to the next digit. When the required time has been entered press *E* to return to the alarm menu.

#### 4.6.10 Access Setpoint: 'AcSP'

This function activates a separate menu that provides direct access to the alarm setpoints when the instrument is in the display mode i.e. displaying speed. See section 4.6.11 for a full description. An operator may therefore adjust the setpoints without having access to the programme and alarm menus. Further protection may be provided by a separate security code.

This direct access menu is enabled and a separate security code entered from the 'AcSP' function in the main programme menu as shown in Fig 4.4 To change the menu parameters select 'AcSP' from the programme menu and press *P*. This will display the enable prompt 'EnbL'.

Pressing *P* again will reveal if the direct access menu is 'On' or 'OFF'. The *Up* or *Down* buttons will toggle the display between the two conditions.

If 'OFF' is selected, the operator will not have access to the setpoints from the display mode. Return to the 'AcSP' prompt in the main menu by pressing *E* twice.

If 'On' is selected, the operator will have direct access to the alarm setpoints from the display mode via a separate optional security code. To define this four digit numeric code press *E* to return to the 'EnbL' prompt followed by the *Up* or *Down* button to select the access code prompt 'AcCd'. Pressing *P* will then reveal the current security code with one digit flashing. The code may be changed by operating the *Up* or *Down* push-buttons and pressing the *P* button to transfer control to the next digit. Finally press *E* twice to enter the new security code and return to the 'AcSP' prompt in the programme menu.

Entering code 0000 will disable the security code allowing direct access to the setpoints in the display mode by pressing the *P* and *Up* buttons simultaneously.

New instruments with alarms are supplied with the security code set to 0000

#### 4.6.11 Adjusting alarm setpoints from the display mode

Access to the two alarm setpoints from the instrument display mode is obtained by operating the *P* and *Up* push-buttons simultaneously as shown in Fig 4.5. If the setpoints are not protected by a security code the alarm setpoint prompt 'SPS1' or 'SPH1' will be displayed, depending upon whether alarm 1 has been programmed as a speed or run-time alarm. If the setpoints are protected by a security code, 'COde' will be displayed first. Pressing *P* again will enable the alarm security code to be entered digit by digit using the *Up* and *Down* buttons to change the flashing digit and the *P* push-button to move control to the next digit. If the correct code is entered pressing *E* will then cause alarm setpoint prompt 'SPx1' to be displayed. If an incorrect security code is entered, or a button is not pressed within ten seconds, the instrument will automatically return to the display mode.

Once within the menu pressing the *Up* or *Down* buttons will toggle the display between the two alarm setpoint prompts 'SPx1' and 'SPx2'.

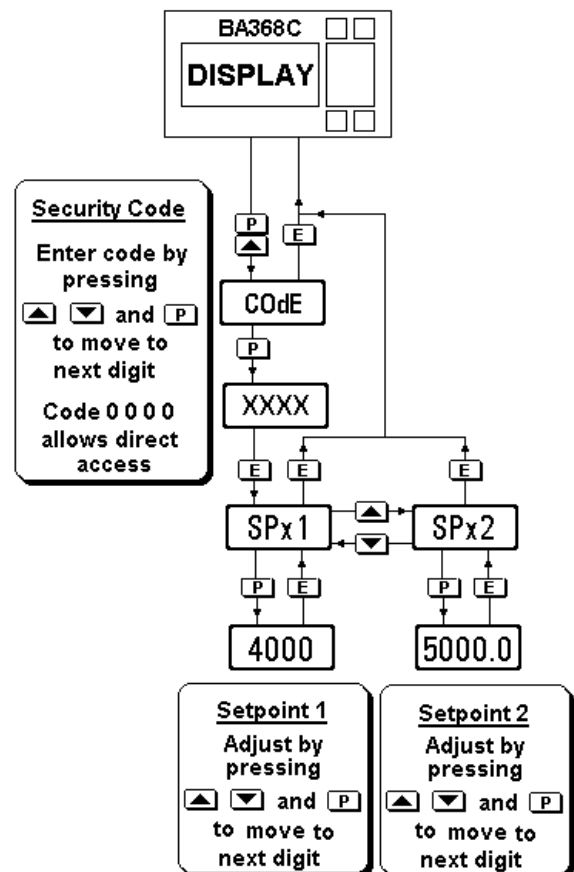

Fig 4.5 Setpoint adjustment from the display mode

To adjust an alarm setpoint select 'SPx1' or 'SPx2' and press *P* which will reveal the current setting. Each digit of the setpoint may be adjusted using the *Up* and *Down* push-buttons, and the *P* button to move control to the next digit. When the required setpoint has been entered, pressing *E* will return the display to the 'SPx1' or 'SPx2' prompt from which the other setpoint may be selected, or the instrument may be returned to the display mode by pressing *E* again.

**Note:** Direct access to the alarm and control output setpoints is only available when the menu is enabled - see section 4.6.10

#### 4.7 OPTIONAL 4/20mA OUTPUT

The BA368C can be supplied with an optional 4/20mA output which may be programmed to produce an analogue output proportional to the whole or part of the speed display. See section 1.9.5.1 for intrinsic safety details.

##### 4.7.1 Programming and adjustment

The main tachometer programme menu is extended as shown in Fig 4.6 to accommodate the 4/20mA calibration functions.

The '4-20 OP' programme function allows the 4/20mA output current to correspond to any speed display. e.g. 4mA could represent 0rpm and 20mA 500rpm.

To calibrate the 4/20mA output current, enter the programme mode by operating the *P* and *E* push-buttons simultaneously. If the instrument is not protected by a security code the first parameter 'Function' will be displayed. Enter the security code if the instrument is protected.

Using the *Up* or *Down* push button select the function '4-20 OP' and press *P* which will result in the BA368C displaying '4.000', this is the prompt for setting the speed display corresponding to an output current of 4.000mA. Pressing *P* will reveal the existing setting with the most significant digit flashing. The decimal point will be fixed in the position already defined for the speed display by the 'd.P' function. The value of the flashing digit may be changed by pressing the *Up* or *Down* buttons. When this digit is set as required, pressing *P* will transfer control to the next digit.

When the required speed has been entered, press the *E* button to return to the '4.000' prompt.

To enter the speed display at which the output current will be 20.000mA, press the *Up* or *Down* button to select the '20.000' prompt followed by *P* to reveal the current setting. This may be changed in the same way as the 4mA setting. When set as required, press *E* three times to return to the display mode via the '20.000' and '4-20 OP' prompts.

The 4/20mA output may be calibrated to increase or decrease as the speed display increases, and most instruments will produce a linear output between 3.5 and 22mA.

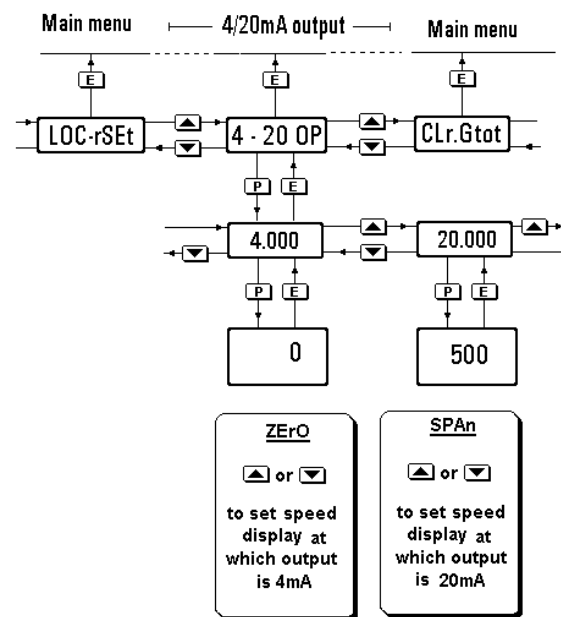

Fig 4.6 4/20mA output programme structure

**Note:** If the speed display calibration is changed by adjusting the rotational scale factor 'r SCALE', the timebase 't-bASE', or the position of the displayed decimal point, the 4/20mA output will automatically be set to give a constant 3.5mA output irrespective of the speed display. The 4/20mA output must therefore always be recalibrated following recalibration of the speed display.

#### 4.8 CALIBRATION EXAMPLE

A BA368C is required to display the speed of a rotating shaft in revolutions per minute with a resolution of 1rpm. The speed sensor is a magnetic pick-off that produces four voltage pulses per revolution. A run-time display is required, which is to operate when the speed exceeds 5rpm and is to be resettable from the BA368C front panel. To prevent tampering the instrument programme menu is to be protected by security code 1209

The BA368C may be calibrated on-site without disconnection from the power supply or from the magnetic pick-off.

##### Step 1 Enter the programming mode

Put the BA368C in the programming mode by simultaneously pressing *P* and *E*. Assuming a security code has not already been entered the instrument will respond by displaying 'Function' which is the first parameter in the main menu. See Fig 4.3

##### Step 2 Select the instrument function

With 'Function' displayed, press *P* to reveal the existing instrument function. If this is not 'tACHO', select 'tACHO' using the *Up* or *Down* button. To prevent accidental changes the new setting will only be executed after the pass word 'SurE' has been entered.

Press *P* which will produce a display of 'Set nO' with the 'nO' flashing. Using the *Up* or *Down* button change 'nO' to 'YES' and press *P* again which will result in a display of '0000'. Using the *Up* or *Down* button to adjust each digit and the *P* push-button to transfer control to the next digit, enter the pass word SurE. **Note:** S is entered as 5.

Finally, press *E* which will execute the function change and return the instrument to the 'Function' prompt in the main menu.

##### Step 3 Select the type of input

Using the *Up* or *Down* button scroll through the main menu until 'InPut' is displayed; press *P* to reveal the existing setting. Using the *Up* or *Down* buttons select 'COIL', the input for a magnetic pick-off, and then return to the 'InPut' prompt in the main menu by pressing *E*.

##### Step 4 Position of decimal point

In this example the BA368C is displaying rotary speed and no display decimal point is required. Select 'd.P.' from the main menu and press *P*. The display will be activated with one digit plus the following decimal point flashing. Press the *Up* or *Down* button until the least significant digit (right hand digit) is flashing which will result in no decimal point being displayed.

Finally press *E* to return to the 'd.P.' prompt in the main menu.

##### Step 5 Enter the rotational scaling factor

In this example the magnetic pick-off produces four voltage pulses per revolution, the instrument rotational scaling factor must therefore be set to 4.0

Select 'r SCALE' from the main menu and press *P* which will show the current figure with one digit flashing. To position the decimal point, operate the *P* push-button to move the flashing digit to the second least significant digit. Pressing the *Up* and *Down* buttons simultaneously will then fix the decimal point in front of the least significant digit.

Using the *Up* and *Down* buttons to adjust each digit in turn and the *P* button to transfer control between digits, enter 4.0 Finally return to the 'r SCALE' prompt in the main menu by pressing *E*.

##### Step 6 Set the display timebase

Select 't-bASE' from the main menu and press *P* to show the current setting. In this example rotary speed is required in revolutions per minute. Using the *Up* or *Down* button scroll through the three options and select 'tb-60' which will multiply the rate display by 60 to provide a display in revolutions per minute (rpm). Return to the 't-bASE' prompt in the main menu by pressing *E*.

**Step 7 Adjust the display filter**

The speed display filter parameters should be adjusted experimentally after installation to provide a stable speed display with an acceptable step response.

During commissioning it is recommended that initially the second digit of the filter parameters is set to 0 (step response off) and the first digit (amount of filtering) is adjusted to provide acceptable speed display stability. The second digit should then be increased until acceptable speed display stability is once again achieved.

To adjust the filter parameters select 'FILtEr' from the main menu and press *P* to reveal the current setting. The first digit will be flashing and may be adjusted using the *Up* or *Down* button. The *P* button will transfer control to the second digit. When both are set as required, return to the 'FILtEr' prompt in the main menu by pressing *E*.

**Note:** While adjusting the filter, the speed is shown on the lower display so that stability can be assessed.

**Step 8 Turn the run-time display on**

In this example the run-time display is required so the lower display must be switched on.

Select 'dISPLAY.2' from the main menu and press *P* which will reveal if it is turned 'On' or 'OFF'. Using the *Up* or *Down* button toggle the display to 'On' and press *E* to return to the 'dISPLAY.2' prompt.

**Step 9 Define the clip off threshold**

The run-time display is required to operate when rotational speed exceeds 5rpm. Select 'CLIP-OFF' from the main menu and press *P* which will show the current value with one digit flashing. Using the *Up* and *Down* buttons to adjust each digit in turn and the *P* button to transfer control between digits, enter 5. Finally return to the 'CLIP-OFF' prompt in the main menu by pressing *E*.

**Step 10 Turn local reset on**

In this example the operator is required to zero the run-time display from the instrument front panel. The local reset function should therefore be turned on.

Select 'LOC-rSEt' from the main menu and press *P* which will reveal if it is turned 'On' or 'OFF'. Using the *Up* or *Down* button toggle the display to 'On' and press *E* to return to the 'LOC-rSEt' prompt.

**Step 11 Reset the run time grand total**

Before completing commissioning the grand total run time should be reset to zero. Select 'CLr.Gtot' from the main menu and press *P* which will cause the instrument to display 'Clr. no'. Toggle this to 'CLr. YES' using the *Up* or *Down* push-buttons and press *P* which will result in a '0000' prompt. Using the *Up*, and *Down* buttons and the *P* button to move to the next digit, confirm the request by entering the password 'SurE'. Note: S is entered as 5. Pressing *E* will then reset the grand total counter to zero and return the instrument to the 'CLr. Gtot' prompt in the main menu.

**Step 12 Define the security code**

Defining a security code prevents unauthorised access to the programme functions. Select 'COdE' from the main menu and press *P* which will reveal the existing security code. Using the *Up* and *Down* buttons enter the new code 1209 digit by digit. The *P* button will transfer control between digits. When the new code has been entered, press *E* to return to the main programme menu.

**Step 13 Return to the display mode**

Following completion of programming and calibration, return the BA368C to the display mode by pressing *E*. All the programming functions will now be stored in permanent memory and will be protected from accidental or unauthorised adjustment by the security code.

## 4.9 MAINTENANCE

### 4.9.1 Fault finding during commissioning

If a BA368C tachometer fails to function during commissioning the following procedure should be followed:

Symptom	Cause	Check:
No display	Incorrect wiring Note: Terminals 2, 4 & 8 are interconnected within the BA368C	That there is between 10 and 28V on terminals 1 & 2 with terminal 1 positive.
Speed display always zero	Incorrect programming or input wiring	That instrument has been programmed for the transducer in use, and that it is connected to terminals 3 & 4 with terminal 3 positive.
No run-time display	Run-time display not switched on.	Programming see 4.5.5
Run-time display always zero	Clip-off incorrectly set.  Reset terminals connected together	Programming see 4.5.9  Wiring & reset switch.
Unable to enter programme mode	Incorrect security code	That correct security code is being used, or fit security link in override position. See Fig 1.4

If a BA368C tachometer fails after it has been functioning correctly, the following table may help to identify the cause of the failure.

Symptom	Cause	Check:
No display	No power supply.	That there is between 10 and 28V on terminals 1 & 2.
Speed display always zero	Transducer or associated wiring has been damaged.	Presence of pulse signal between input terminals 3 & 4.
Run-time display not functioning	Remote reset contact closed	That remote reset contact is not closed or associated wiring damaged.
Colon appears between digits in display	Display has overranged	Calibration and change to reduce size of display

If this procedure does not reveal the cause of the fault, it is recommended that the instrument is returned to BEKA or to our agent in your area for repair.

### 4.9.2 Fault finding after commissioning

#### ENSURE PLANT SAFETY BEFORE STARTING MAINTENANCE

**Live maintenance is permitted on intrinsically safe equipment installed in a hazardous area, but only certified test equipment should be used unless a gas clearance certificate is available.**

#### 4.10 INDEX FOR TACHOMETER SECTION

Subject	Section	Subject	Section
ATEX intrinsic safety certification	1.4; 4.2	Rotational scale factor	4.5.6
Alarms optional	4.6	Run time	4.1
Access setpoint	4.3.5; 4.4.5	Resetting	4.3.3; 4.4.3
Delay	4.6.10	Resetting grand total	4.5.10
Enable	4.6.8		4.5.11
Function	4.6.2	Security	
Hysteresis	4.6.5	Code	4.5.12
Intrinsic safety	4.6.7	Override link	1.6.1
Normally open or closed	1.9.3.2	Servicing	1.7
Setpoint	4.6.6	Timebase	4.5.7
Silence time	4.6.4	Zener barriers use with	4.3
Solid state outputs	4.6.9	4/20mA output optional	4,7
Type	1.9.3.1	Intrinsic safety	4.3.4; 4.4.4
Backlight optional	4.6.3	Programming & adjustment	1.9.5.1
Calibration	1.9.6		4.7.1; Fig 4.6
Clip off	4.5; Fig 4.3		
Controls	4.5.9		
Decimal points	4.1.2		
Display	4.5.4		
Filter	4.1.3		
Lower (run-time)	4.5.8		
Function of instrument	4.5.5		
Guarantee	4.5.2		
Galvanic isolator use with	1.7.2		
Input	4.4		
Installation	4.3.2; 4.4.2;		
Local run-time reset	4.5.3		
Location	1.5		
Maintenance	4.5.10		
Routine	1.5.1		
Power supply	4.9		
	1.7.1		
	4.3.1; 4.4.1		





## Section 5 Use as a clock

### CONTENTS

- 5.1 Description**
  - 5.1.1 Initialisation & loss of power
  - 5.1.2 Controls
  - 5.1.3 Displays
- 5.2 System certificates**
- 5.3 Use with Zener barriers**
  - 5.3.1 Power supply
  - 5.3.2 Synchronisation
  - 5.3.3 Optional control outputs
- 5.4 Use with galvanic isolators**
  - 5.4.1 Power supply
  - 5.4.2 Synchronisation
  - 5.4.3 Optional control outputs
- 5.5 Programming**
  - 5.5.1 Accessing programme functions.
  - 5.5.2 Function of instrument
  - 5.5.3 Display format and units
  - 5.5.4 Set display time
  - 5.5.5 Set reset time
  - 5.5.6 Security code
  - 5.5.7 Control output enable
  - 5.5.8 Setpoint times
  - 5.5.9 Access setpoints
  - 5.5.10 Adjusting control output setpoints when displaying time.
- 5.6 Application**
  - 5.6.1 Calibration
- 5.7 Maintenance**
  - 5.7.1 Fault finding during commissioning.
  - 5.7.2 Fault finding after commissioning.
- 5.8 Index for Clock section**

## 5.1 DESCRIPTION

When programmed as a clock the BA368C will display local time in twelve or in twenty four hour format. Hours and minutes, or hours, minutes and seconds may be displayed. The displayed time can be adjusted via the front panel push-buttons which may be protected by a user definable four digit security code to prevent unauthorised or accidental adjustment.

The clock may be synchronised to an external time standard via the instrument's reset terminals. When these two terminals are connected together by an external switch contact, the clock display will be reset to a preprogrammed time. When the contacts open the clock will continue running from the preprogrammed time.

When fitted with the optional control outputs the clock can be programmed to turn each solid state output on and off twice during each twenty four hour period.

### 5.1.1 Initialisation and loss of power

When power is applied to a BA368C clock, following initialisation, the instrument will display a flashing 'A 12:00' or '00:00' depending upon whether a twelve or twenty four hour display has been selected. Seconds will also be shown if selected. The clock will not start until a display time has been entered, or the remote reset contacts are closed and opened to synchronise the clock display.

If during normal operation the power supply is interrupted for more than 30ms, the display will return to the flashing condition following initialisation.

### 5.1.2 Controls

The BA368C clock is controlled and calibrated via four front panel push-button switches. In the display mode i.e. when the instrument is displaying time the switch functions are:

**Down+P** While these buttons are pushed the instrument will display the firmware and version numbers plus the programmed function.

**Note:** When optional control outputs are fitted, the BA368C clock may be programmed to provide direct access to the setpoints from the display mode when the *P + Up* push-buttons are operated.  
– see section 5.5.10

### 5.1.3 Displays

The BA368C clock has a single digital display plus annunciators.

**Time display** Shows time in selected format

**Reset Annunciator** Activated while instrument is being synchronised.

**Control output Annunciators** Activated when optional control output is closed.

## 5.2 SYSTEM CERTIFICATES

In addition to the ATEX EC-Type Examination Certificate, ITS have issued two system certificates. One defines how the BA368C may be used with Zener barriers and the other with galvanic isolators.

Interface	Certificate No
Zener barriers	Ex01E2007
Galvanic isolators	Ex01E2008

This section interprets these system certificates and illustrates how to design clock systems with Zener barriers and galvanic isolators.

System certificates are Certificates of Conformity which are primarily issued for guidance in the UK. They do not form part of certification to the European ATEX Directive.

### 5.3 USE WITH ZENER BARRIERS

Zener barriers are the least expensive intrinsically safe interface between a safe and hazardous area. However, they do not provide isolation and require a high integrity earth connection that may be expensive to install. For a single BA368C clock it may be less expensive and easier to use galvanic isolators especially when a high integrity earth connection is not already available.

Any certified Zener barriers may be used with the BA368C providing their output parameters do not exceed the input parameters of the terminals to which they are connected. Only one polarity of Zener barrier i.e. positive or negative, may be used with each instrument.

To assist with system design, the Zener barrier system certificate specifies the maximum output parameters of the Zener barriers that may be connected to the BA368C and defines the maximum cable parameters. Diode return barriers are identified by manufacturers type number, although alternatives may be used.

The basic system used for all BA368C hazardous area clock installations is shown in Fig 5.1 Intrinsic safety requirements are explained in section one of this manual which should be read before the system is designed.

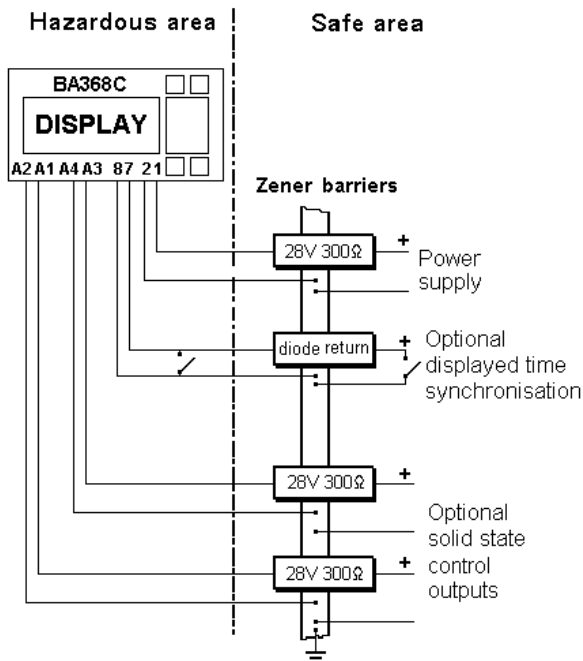

Fig 5.1 Clock installation using barriers

If clock synchronisation is not required and the optional control outputs are not fitted, only a power supply Zener barrier is required.

#### 5.3.1 Power supply

A BA368C is powered from the safe area via a positive polarity 28V 300Ω Zener barrier which will have an end-to-end resistance of about 340Ω. When operating as a clock the BA368C consumes approximately 15mA and requires a minimum voltage of 10V between terminals 1 and 2. The supply voltage in the safe area must therefore be between 16V and the maximum working voltage of the Zener barrier – usually about 26V.

#### 5.3.2 Synchronisation

When terminals 7 & 8 are connected together the time displayed by the BA368C will be set to the preprogrammed reset time. The clock function will be inhibited until the contacts are opened when the clock will restart. To achieve reliable resetting the contacts must close for at least one second. This function enables the BA368C clock to be synchronised with a master clock once every 24 hours.

Resetting may be accomplished by any mechanically operated switch located in the hazardous area providing it can withstand a 500V rms insulation test to earth for one minute. No Zener barrier is required.

The BA368C may also be reset from within the safe area. Any switch may be used but a Zener barrier is required to transfer the contact closure into the hazardous area. A diode return barrier may be used which can be combined with the supply barrier so that only one dual channel device is required. The system certificate lists some of devices that may be used.

Figs 5.1 and 5.2 illustrate how the BA368C clock may be synchronised from both the safe and the hazardous area.

#### 5.3.3 Optional control outputs

The BA368C can be supplied with two isolated solid state control outputs. Each output may be programmed to turn on and off twice during a twenty four hour period. These outputs may be used to switch certified intrinsically safe devices within the hazardous area, or the contacts may be transferred to the safe area via a Zener barrier.

## 5.4 USE WITH GALVANIC ISOLATORS

Galvanic isolators are probably the easiest intrinsically safe interface to use as they provide isolation and do not require a high integrity earth connection.

Any EEx ia IIC certified intrinsically safe galvanic isolators may be used with the BA368C providing the output parameters do not exceed the input parameters of the terminals to which they are connected.

To assist with system design, the galvanic isolator system certificate lists some of the isolators that may be used and defines the maximum permitted cable parameters.

Fig 5.2 illustrates the basic circuit that is used for all BA368C clock installations protected by galvanic isolators.

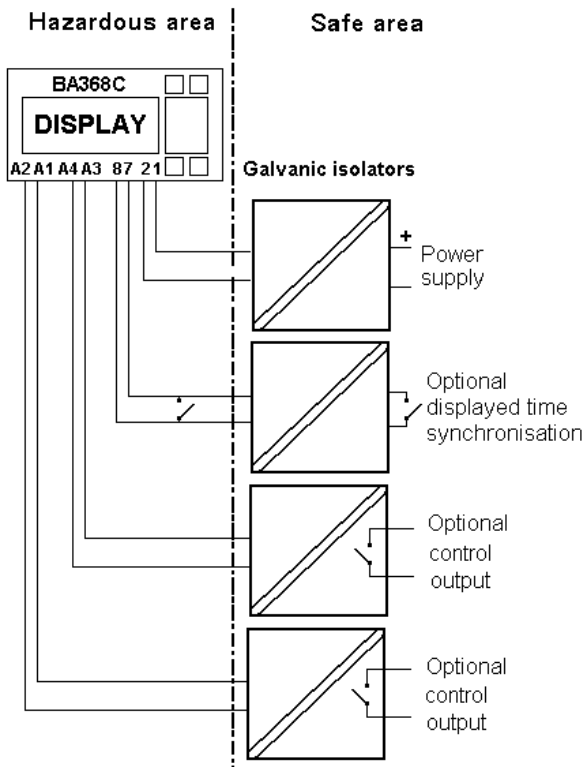

Fig 5.2 Basic clock circuit using isolators

### 5.4.1 Power supply

The BA368C galvanic isolator system certificate lists a wide range of certified galvanic isolators that may be used to power the instrument. If using the entity concept to select an isolator, in addition to matching the safety parameters, the isolator must be capable of supplying 10V dc minimum at 15mA to the BA368C.

### 5.4.2 Synchronisation

When terminals 7 & 8 are connected together the displayed time will be automatically set to the preprogrammed reset time. The clock will be inhibited until terminals 7 & 8 are disconnected from each other, when it will restart from the preprogrammed time. To achieve reliable synchronisation terminals 7 & 8 should be connected together by a pair of contacts which close for at least one second. This function enables one or more BA368C clocks to be synchronised with a master clock once every 24 hours.

Synchronisation may be accomplished by any mechanically operated switch located in the hazardous area providing it can withstand a 500V rms insulation test to earth for one minute. No galvanic isolator is required.

The BA368C may also be synchronised from within the safe area. Any switch may be used, but a galvanic isolator or intrinsically safe relay is required to transfer the contact closure into the hazardous area. See system certificate for a list of some devices that may be used. Fig 5.2 illustrates how the BA368C may be synchronised from both the safe and the hazardous area.

### 5.4.3 Optional control outputs

The BA368C can be supplied with two isolated solid state control outputs. Each output may be programmed to turn on and off twice during a twenty four hour period. These outputs may be used to switch certified intrinsically safe devices within the hazardous area, or the contacts may be transferred to the safe area via a galvanic isolator.

## 5.5 PROGRAMMING

Throughout this manual push-buttons are shown in italics e.g. *P* or *Up* push-button, and legends displayed by the instrument are shown within inverted commas e.g. 'SEt' and 'dISPLAY'.

### 5.5.1 Accessing programme functions

Access to the programme menu is obtained by operating the *P* and *E* push-buttons simultaneously. If the BA368C is not protected by a security code the first parameter 'Function' will be displayed. If a security code other than the default code 0000 has already been entered, the instrument will display 'COdE'. Press *P* to clear this prompt and enter the security code for the instrument using the *Up* or *Down* push-button to adjust each digit, and the *P* push-button to move control to the next digit. If the correct code has been entered pressing *E* will cause the first parameter 'Function' to be displayed. If an incorrect code is entered, or a push-button is not operated within ten seconds, the instrument will automatically return to the display mode.

Once within the main programme menu the required parameter can be reached by scrolling through the menu using the *Up* and *Down* push-buttons as shown by the clock programme structure shown in Fig 5.3.

This section summarises all the clock programmable parameters including those for the optional control outputs. When read in conjunction with Fig 5.3 it provides a quick aid for programming the instrument. If more detail is required, each section contains a reference to a full description of the function.

## SUMMARY OF PROGRAMME FUNCTIONS

<u>Display</u>	<u>Description of function</u>
<b>'Function'</b>	<p><b>Function of instrument</b> Enables the BA368C to be conditioned as a counter, timer, tachometer or clock. After making the selection 'SurE' has to be entered to confirm the instruction Select 'CLOC' to enable the clock functions. See section 5.5.2</p>
<b>'dISPLAY'</b>	<p><b>Display format and units</b> Allows a 12 or 24 hour clock display to be selected with or without seconds Select: 12:00 for 12 hours without seconds 12:00:00 for 12 hours with seconds 24:00 for 24 hours without seconds 24:00:00 for 24 hours with seconds See section 5.5.3</p>
<b>'SEt'</b>	<p><b>Set display time</b> Enables the displayed time to be adjusted, the clock resumes operating when the SEt menu is exited. See section 5.5.4</p>
<b>'rSEt t'</b>	<p><b>Set reset time</b> Enables the reset time to be adjusted so that the BA368C can be synchronised with an external master clock. See section 5.5.5</p>
<b>'COdE'</b>	<p><b>Security code</b> Defines a four digit numeric code that must be entered to gain access to the programmable functions. Default code 0000 disables the security function and allows unrestricted access to all programmable functions. See section 5.5.6</p>

<b><u>Display</u></b>	<b><u>Description of function</u></b>
<b>'EnbL'</b>	<p><b>Control output enable *</b>            Allows one or two switching cycles per 24 hours to be selected or the optional control output to be disabled.            See section 5.5.7</p>
<b>'OP1:On1'</b>	<p><b>Setpoint *</b>            Defines the time at which control output 1 turns on for the first time.            See section 5.5.8</p>
<b>'OP1:OFF1'</b>	<p><b>Setpoint *</b>            Defines the time at which control output 1 turns off for the first time.            See section 5.5.8</p>
<b>'OP1:On2'</b>	<p><b>Setpoint *</b>            Defines the time at which control output 1 turns on for the second time.            See section 5.5.8</p>
<b>'OP1:OFF2'</b>	<p><b>Setpoint *</b>            Defines the time at which control output 1 turns off for the second time.            See section 5.5.8</p>
<b>'AcSP'</b>	<p><b>Access setpoint *</b>            Sub-menu that enables direct access to the control output setpoints from the display mode and defines a separate security code.            See section 5.5.9</p>

**Note:** Functions marked with an asterisk \* are only included when the optional control outputs are fitted.

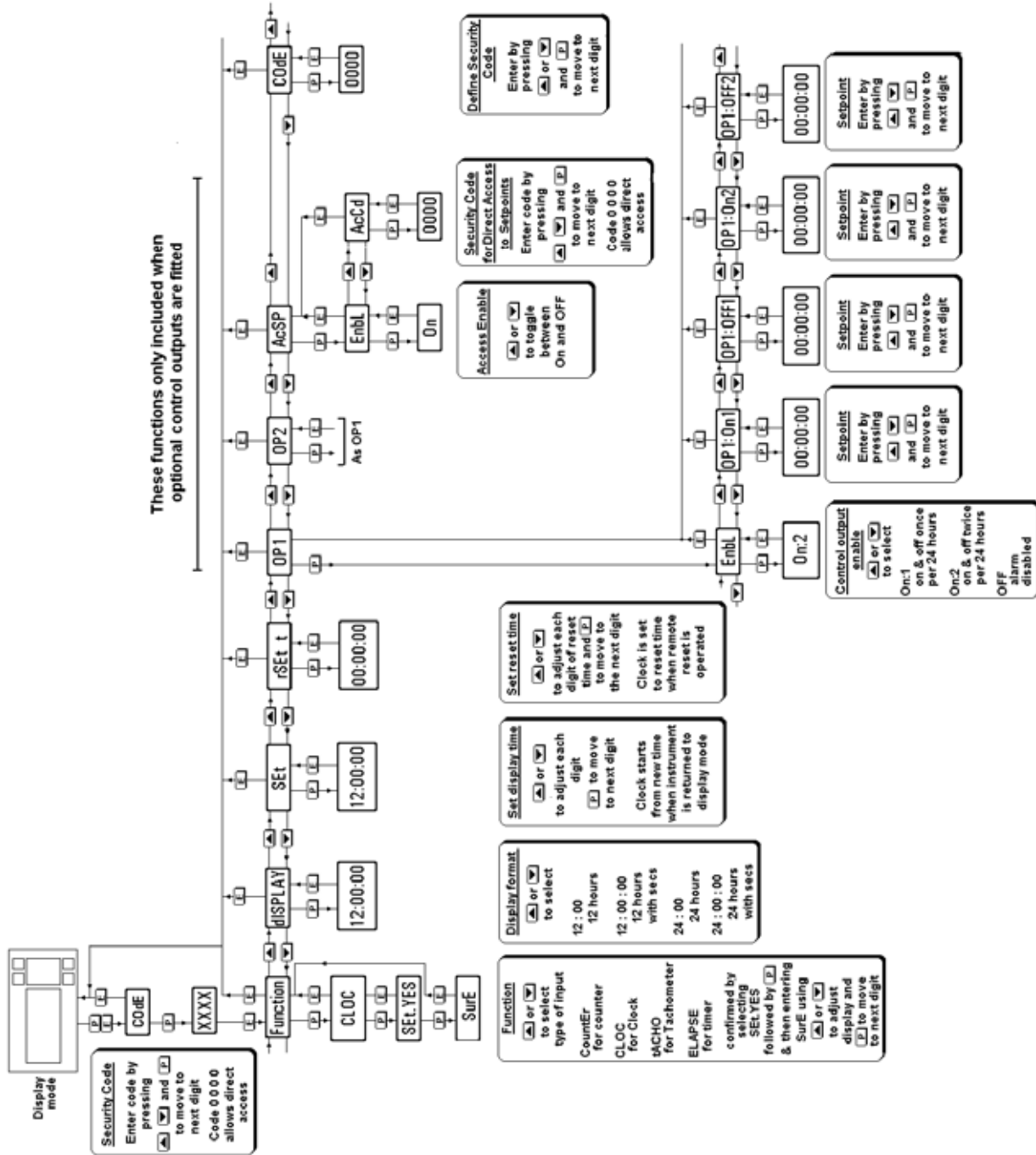

Fig 5.3 Clock programme structure

### 5.5.2 Function of instrument: 'Function'

This is the first function in the programme menu which conditions the instrument as a counter, timer, tachometer or as a clock.

#### CAUTION

**This function must be entered before any of the other parameters are programmed. It is protected by a password to prevent accidental changes.**

To define the function of the instrument select 'Function' from the main menu and press *P* which will reveal the existing setting. Pressing the *Up* or *Down* button will scroll through the four options:

Display	Instrument function
'CountEr'	Counter
'CLOC'	Clock
'tACHO'	Tachometer
'ELAPSE'	Timer

When 'CLOC' is displayed, press *P* which will result in 'Set.nO' being displayed. To proceed press *Up* or *Down* which will change this to 'Set.YES'. To confirm the function change, press *P* which will result in prompt 'Set 0000' with one digit flashing. Using the *Up*, and *Down* buttons and the *P* button to move to the next digit, enter the password 'SurE'. Note 'S' is entered as '5'. Finally, pressing *E* will execute the change to a Clock and return the display to the 'Function' prompt in the main menu.

### 5.5.3 Display format & units: 'dISPLAY'

This parameter allows a twelve or twenty four hour format with or without seconds to be selected.

To check or change the units select 'dISPLAY' from the main menu and press *P* which will reveal the current setting. Pressing the *Up* or *Down* button will scroll through the four options:

Display	Clock format
'12:00'	12 hours
'12:00:00'	12 hours with seconds
'24:00'	24 hours
'24:00:00'	24 hours with seconds

Both the twelve hour clock displays are prefixed by an 'A' or a 'P' to denote am or pm. When the required format has been selected, press *E* to enter and return the instrument to the main menu.

**Note:** When only hours and minutes are being displayed, the displayed colon flashes to show that the clock is functioning.

### 5.5.4 Set display time: 'SEt'

To set the displayed time select 'SEt' from the main menu and press *P* to reveal the existing display with one digit flashing. The value of the flashing digit can be changed by pressing the *Up* or *Down* buttons. When this digit is correct pressing *P* will transfer control to the next digit.

When a twelve hour format has been selected in the 'dISPLAY' function, the displayed time will be prefixed by an 'A' or a 'P' to denote am or pm. This may be changed by pressing *P* until the prefix flashes and then operating the *Up* or *Down* button to set the prefix as required.

When the correct time has been entered, press *E* to restart the clock and return the instrument to the main menu.

**Note:** Seconds are always displayed while the set time is being adjusted.

### 5.5.5 Set reset time: 'rSEt t'

This function enables the BA368C reset time to be adjusted. When terminals 7 & 8 are connected together the time displayed by the BA368C will be automatically set to this preprogrammed reset time. The clock function will remain inhibited until the contacts are opened, when the clock will restart operating from the reset time. This enables the BA368C clock to be synchronised with a master clock once every 24 hours.

To adjust the reset time select 'rSEt t' from the main menu and press *P* to reveal the existing display with one digit flashing. The value of the flashing digit can be changed by pressing the *Up* or *Down* buttons. When this digit is correct pressing *P* will transfer control to the next digit.

When the required time has been entered, press *E* to return to the main menu.

**Note:** Seconds are always displayed while the reset time is being adjusted.

### 5.5.6 Security code: 'CodE'

All clock adjustments may be protected by a four digit security code which must be entered before access to the programme menu is granted. New instruments are programmed with the default security code 0000 that allows unrestricted access to all programming functions without entering a security code.

To enter a new security code select 'COdE' from the menu and press *P* which will cause the instrument to display the current security code.



Each digit of the code can be changed using the *Up* and *Down* push-buttons, and the *P* button to transfer control to the next digit. When the required code has been entered press *E* to return to the main menu. The revised security code will be activated when the clock is returned to the display mode.

If the security code is lost, access to the programmable functions can be obtained by moving the internal security link to the override position. The original security code can then be viewed by selecting 'COdE' from the main menu and pressing *P*. Section 1.6.1 explains how to move the link.

### 5.5.7 Control output enable: 'EnbL'

This function, which appears in each of the two control output sub-menus OP1 and OP2, determines whether the output turns on and off, once or twice every twenty four hours.

To check or change the function select 'EnbL' from the required control output menu and press *P* which will reveal the current setting. Pressing the *Up* or *Down* button will scroll through the three options:

Display	Control output
'OFF'	Control output disabled
'On:1'	Turns on & off once per 24 hours
'On:2'	Turns on & off twice per 24 hours

### 5.5.8 Setpoint times: 'OP1'

Each of the two control outputs has two or four setpoints depending upon whether the output has been programmed to turn on & off once or twice in each 24 hour period. – see 5.5.7

To adjust the setpoints of control output 1 select 'OP1' from the main menu and press *P* which will cause the 'EnbL' prompt to be displayed. Pressing the *Up* button will scroll through the setpoints. There will only be two setpoints if the control output has been conditioned to switch on & off once.

Display	Setpoint
'OP1 : On1'	Time OP1 turns on first time
'OP1 : OFF1'	Time OP1 turns off first time
'OP1 : On2'	Time OP1 turns on second time
'OP1 : OFF2'	Time OP1 turns off second time

When the required setpoint is displayed press *P* to reveal the current setting. Each digit may be adjusted using the *Up* and *Down* push-buttons. The *P* button transfers control to the next digit. When set as required, press *E* to return the sub-menu from which another setpoint may be selected.

**Note:** Seconds are always displayed while the set points are being adjusted.

### 5.5.9 Access Setpoint: 'AcSP'

This function activates a separate menu that provides direct access to the control output setpoints when the clock is in the display mode. See section 5.5.10 for a full description. An operator may therefore adjust the setpoints without having access to the programme menus. Further protection is provided by a separate security code.

This direct access menu is enabled and a separate security code entered from the 'AcSP' function in the main programme menu as shown in Fig 5.3. To change the menu parameters select 'AcSP' from the programme menu and press *P*. This will display the enable prompt 'EnbL'.

Pressing *P* again will reveal if the direct access menu is 'On' or 'OFF'. The *Up* or *Down* buttons will toggle the display between the two conditions.

If 'OFF' is selected, the operator will not have direct access to the setpoints when the BA368C clock is displaying time. Return to the 'AcSP' prompt in the main menu by pressing *E* twice.

If 'On' is selected, the operator will have direct access via a separate menu and optional security code to the control output setpoints when the BA368C is displaying time. To define this four digit numeric code press *E* to return to the 'EnbL' prompt followed by the *Up* or *Down* button to select the access code prompt 'AcCd'. Pressing *P* will then reveal the current security code with one digit flashing. The code may be changed by operating the *Up* or *Down* push-buttons and pressing the *P* button to transfer control to the next digit. Finally press *E* twice to enter the new security code and return to the 'AcSP' prompt in the programme menu.

Entering code 0000 will disable the security code allowing direct access to the setpoints in the display mode by pressing the *P* and *Up* buttons simultaneously.

New instruments with control outputs are supplied with the security code set to 0000

**5.5.10 Adjusting control output setpoints while displaying time**

Direct access to the control output setpoints from the clock display mode is obtained by operating the *P* and *Up* push-buttons simultaneously as shown in Fig 5.4. If the setpoints are not protected by a security code, the control output setpoint prompt 'OP1: On1' will be displayed. If the setpoints are protected by a security code, 'COde' will be displayed first. Pressing *P* again will enable the control output security code to be entered digit by digit using the *Up* and *Down* buttons to change the flashing digit and the *P* push-button to move control to the next digit. If the correct code is entered pressing *E* will then cause alarm setpoint prompt 'OP1: On1' to be displayed. If an incorrect security code is entered, or a button is not pressed within ten seconds, the instrument will automatically return to the display mode.

Once within the menu pressing the *Up* or *Down* buttons will scroll through all the setpoints. When the required setpoint is displayed pressing *P* will reveal the existing setpoint time. This may be adjusted using the *Up* and *Down* push-buttons and the *P* button to move control to the next digit. When the required time has been entered, pressing *E* will return the display to the setpoint identification from which another setpoint may be selected, or the clock may be returned to the display mode by pressing *E* again.

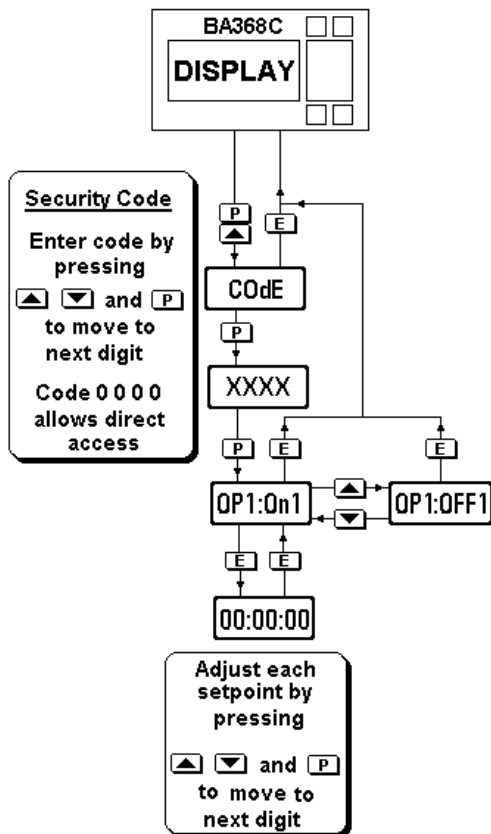

Fig 5.4 Setpoint adjustment from the clock display mode

Each of the two control outputs has two or four setpoints depending upon whether the output has been programmed to turn on & off once or twice in each 24 hour period. – see 5.5.7

**Notes:** Direct access to the control output setpoints is only available when the menu is enabled - see section 5.5.9

Seconds are always displayed while adjusting the setpoints.

**5.6 APPLICATION**

This section describes a typical application in which a 24 hour clock with a HH:MM format is required within a hazardous area. To comply with auditing requirements, this, and a number of other BA368C clocks are to be automatically synchronised at 12:00 each day. To prevent accidental adjustment the instrument programme menu is to be protected by security code 1112

Fig 5.5 shows the simplest Zener barrier interface and illustrates how a number of clocks may be synchronised. Terminals 2 and 8 are interconnected within the BA368C so only one of them needs to be connected to the Zener barrier busbar.

When the synchronising contact is closed all the BA368C clocks will display the programmed reset time, in this example 12:00. When the contacts open all the clocks will start running. This contact may be a PLC output programmed to close at 11:59:58 and to open at 12:00:00

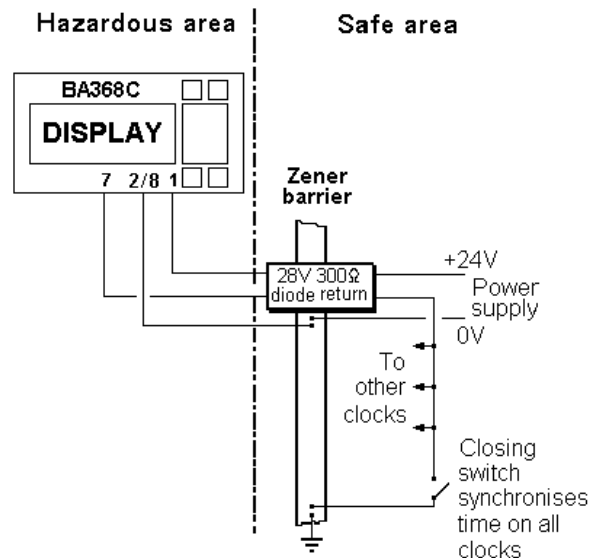

Fig 5.5 Clock application with synchronisation

### 5.6.1 Calibration

The following is a step by step example showing how easy it is to programme a BA368C clock.

#### Step 1 Enter the programming mode

Put the BA368C in the programming mode by simultaneously pressing *P* and *E*. Assuming a security code has not already been entered the instrument will respond by displaying 'Function' which is the first parameter in the main menu. See Fig 5.3

#### Step 2 Select the instrument function

With 'Function' displayed, press *P* to reveal the existing instrument function. If this is not 'CLOC', select 'CLOC' using the *Up* or *Down* button. To prevent accidental changes the new setting will only be executed after the pass word 'SurE' has been entered.

Press *P* which will produce a display of 'Set nO' with the 'nO' flashing. Using the *uP* or *Down* button change 'nO' to 'YES' and press *P* again which will result in a display of '0000'. Using the *Up* or *Down* button to adjust each digit and the *P* push-button to transfer control to the next digit, enter the pass word SurE. Note: S is entered as 5.

Finally, press *E* which will execute the function change and return the instrument to the 'Function' prompt in the main menu.

#### Step 3 Select the display format

Using the *Up* or *Down* button scroll through the main menu until 'DISPLAY' is found; press *P* to reveal the existing setting. Using the *Up* or *Down* buttons select '24:00', which will provide a 24 hour format without seconds. Finally return to the main menu by pressing *E*.

#### Step 4 Setting the reset time

Using the *Up* or *Down* button scroll through the main menu until 'rSEt t' is displayed; press *P* to reveal the existing setting with one digit flashing.

Using the *Up* or *Down* button to adjust the flashing digit and the *P* button to transfer control to the next digit, enter 12:00 the required reset time. Finally pressing *E* will return the instrument to the 'rSEt t' prompt in the main menu.

#### Step 5 Define the security code

The security code prevents unauthorised access to the programme functions. Select 'COdE' from the main menu and press *P* which will reveal the existing security code. Using the *Up* and *Down* buttons enter the new code 1112 digit by digit. The *P* button will transfer control between digits. When the new code has been entered, press *E* to return to the main programme menu.

#### Step 6 Setting the displayed time

Using the *Up* or *Down* button scroll through the main menu until 'SEt' is displayed. Pressing *P* will reveal the clock display with one digit flashing. The current time can be entered by adjusting the flashing digit using the *Up* or *Down* button and the *P* button to transfer control to the next digit. When set as required, pressing *E* twice will start the clock and return the instrument to the display mode.

## 5.7 MAINTENANCE

### 5.7.1 Fault finding during commissioning

If a BA368C clock fails to function during commissioning the following procedure should be followed:

Symptom	Cause	Check:
No display	Incorrect wiring Note: Terminals 2 & 8 are interconnected within the BA368C	That there is between 10 and 28V on terminals 1 & 2 with terminal 1 positive.
Display is flashing	Display time has not been set	Section 5.5.4 and set clock display
Displaying a fixed time	Reset terminals connected together	Wiring and reset switch
Unable to enter programme mode	Incorrect security code	That correct security code is being used, or fit security link in override position. See Fig 1.4

### 5.7.2 Fault finding after commissioning

#### ENSURE PLANT SAFETY BEFORE STARTING MAINTENANCE

**Live maintenance is permitted on intrinsically safe equipment installed in a hazardous area, but only certified test equipment should be used unless a gas clearance certificate is available.**

If a BA368C clock fails after it has been functioning correctly, the following table may help to identify the cause of the failure.

Symptom	Cause	Check:
No display	No power supply.	That there is between 10 and 28V on terminals 1 & 2.
Display is flashing	Power supply has been interrupted	Supply security and set clock display. See 5.5.4
Displaying a fixed time	Remote reset contact closed	That remote reset contact is not closed or associated wiring damaged.

If this procedure does not reveal the cause of the fault, it is recommended that the instrument is returned to BEKA or to our agent in your area for repair.

## 5.8 INDEX FOR CLOCK SECTION

<b>Subject</b>	<b>Section</b>
ATEX intrinsic safety certification	1.4; 5.2
Backlight optional	1.9.6
Controls	5.1.2
Control outputs optional	5.3.3; 5.4.3
Enable	5.5.7
Intrinsic safety	1.9.3.2
Setpoint times	5.5.8
When displaying time	5.5.9; 5.5.10
Solid state outputs	1.9.3.1
Display	5.1.3
Format & units	5.5.3
Set time	5.5.4
Function of instrument	5.5.2
Guarantee	1.7.2
Galvanic isolator use with	5.4
Installation	1.5
Location	1.5.1
Loss of power	5.1.1
Maintenance	5.7
Routine	1.7.1
Power supply	5.3.1; 5.4.1
Programming	5.5; Fig 5.3
Accessing	5.5.1
Security	
Code	5.5.6
Override link	1.6.1
Servicing	1.7
Synchronisation	5.3.2; 5.4.2
Reset time	5.5.5
Zener barriers use with	5.3